

Masoneilan™

35002 Series Camflex™ II

Rotary Control Valve

Instruction Manual (Rev.E)

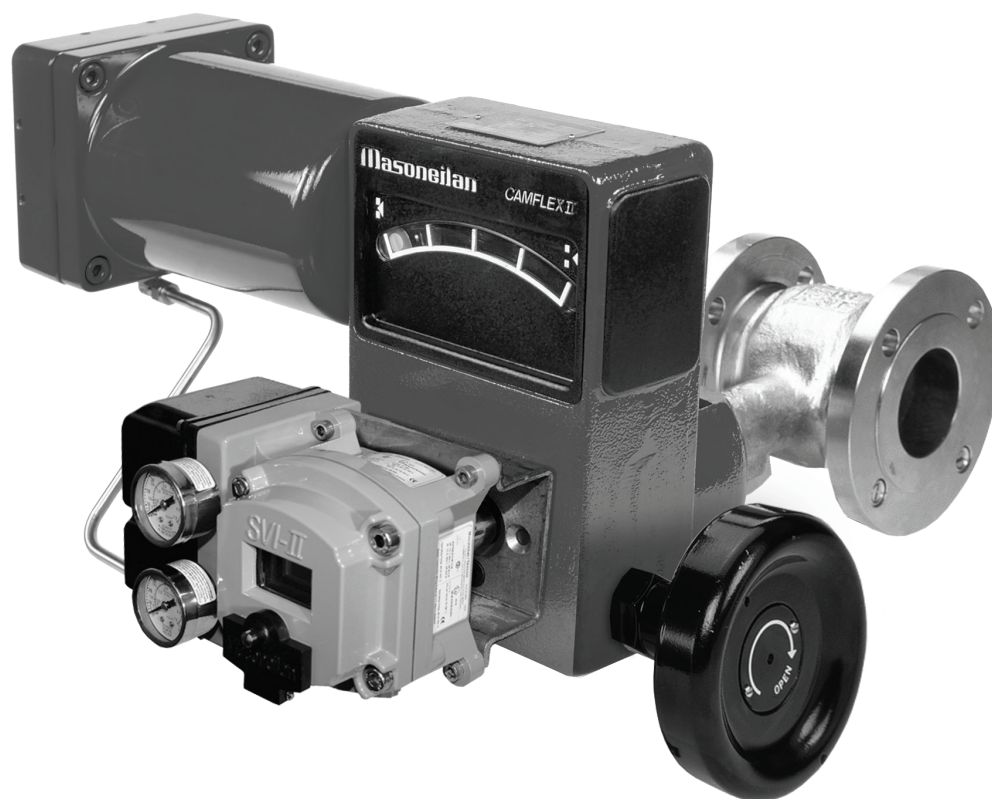

THESE INSTRUCTIONS PROVIDE THE CUSTOMER/OPERATOR WITH IMPORTANT PROJECT-SPECIFIC REFERENCE INFORMATION IN ADDITION TO THE CUSTOMER/OPERATOR'S NORMAL OPERATION AND MAINTENANCE PROCEDURES. SINCE OPERATION AND MAINTENANCE PHILOSOPHIES VARY, BAKER HUGHES (AND ITS SUBSIDIARIES AND AFFILIATES) DOES NOT ATTEMPT TO DICTATE SPECIFIC PROCEDURES, BUT TO PROVIDE BASIC LIMITATIONS AND REQUIREMENTS CREATED BY THE TYPE OF EQUIPMENT PROVIDED.

THESE INSTRUCTIONS ASSUME THAT OPERATORS ALREADY HAVE A GENERAL UNDERSTANDING OF THE REQUIREMENTS FOR SAFE OPERATION OF MECHANICAL AND ELECTRICAL EQUIPMENT IN POTENTIALLY HAZARDOUS ENVIRONMENTS. THEREFORE, THESE INSTRUCTIONS SHOULD BE INTERPRETED AND APPLIED IN CONJUNCTION WITH THE SAFETY RULES AND REGULATIONS APPLICABLE AT THE SITE AND THE PARTICULAR REQUIREMENTS FOR OPERATION OF OTHER EQUIPMENT AT THE SITE.

THESE INSTRUCTIONS DO NOT PURPORT TO COVER ALL DETAILS OR VARIATIONS IN EQUIPMENT NOR TO PROVIDE FOR EVERY POSSIBLE CONTINGENCY TO BE MET IN CONNECTION WITH INSTALLATION, OPERATION OR MAINTENANCE. SHOULD FURTHER INFORMATION BE DESIRED OR SHOULD PARTICULAR PROBLEMS ARISE WHICH ARE NOT COVERED SUFFICIENTLY FOR THE CUSTOMER/OPERATOR'S PURPOSES THE MATTER SHOULD BE REFERRED TO BAKER HUGHES.

THE RIGHTS, OBLIGATIONS AND LIABILITIES OF BAKER HUGHES AND THE CUSTOMER/OPERATOR ARE STRICTLY LIMITED TO THOSE EXPRESSLY PROVIDED IN THE CONTRACT RELATING TO THE SUPPLY OF THE EQUIPMENT. NO ADDITIONAL REPRESENTATIONS OR WARRANTIES BY BAKER HUGHES REGARDING THE EQUIPMENT OR ITS USE ARE GIVEN OR IMPLIED BY THE ISSUE OF THESE INSTRUCTIONS.

THESE INSTRUCTIONS ARE FURNISHED TO THE CUSTOMER/OPERATOR SOLELY TO ASSIST IN THE INSTALLATION, TESTING, OPERATION, AND/OR MAINTENANCE OF THE EQUIPMENT DESCRIBED. THIS DOCUMENT SHALL NOT BE REPRODUCED IN WHOLE OR IN PART WITHOUT THE WRITTEN APPROVAL OF BAKER HUGHES.

Table Of Contents

Safety Information	1
About this Manual	1
Warranty	1
1. Introduction	2
2. General	2
3. Principle Of Operation	2
4. Unpacking	3
5. Installation	3
6. Air Supply Piping	4
7. Placing In Service	4
8. Disassembly	4
8.1 Actuator Removal from Body S/A.....	4
8.2 Actuator Complete Disassembly	5
8.3 Valve Body	5
9. Maintenance	7
9.1 Spring Diaphragm Replacement	7
9.2 Body S/A Internal Parts	8
9.3 Yoke Assembly	9
10. Reassembly Procedures	9
10.1 Spring Diaphragm Actuator	9
10.2 Spring Diaphragm Actuator on Body S/A.....	9
10.3 Handwheel Reassembly	10
10.4 Limit Stop Reassembly	10
10.5 Valve Body Reassembly	10
10.6 Seat Ring Alignment.....	11
10.7 DVD Plate Reassembly.....	12
11. Actuator Stem Adjustment	12
12. Changing Body Position	13
13. Changing Actuator Action	14
14. Manual Actuator Option	15
14.1 Disassembly Procedure	15
14.2 Maintenance.....	15
14.3 Reassembly Procedure.....	15

Safety Information

Important - Please read before installation

These instructions contain **DANGER**, **WARNING**, and **CAUTION** labels, where necessary, to alert you to safety related or other important information. Read the instructions carefully before installing and maintaining your control valve. **DANGER** and **WARNING** hazards are related to personal injury. **CAUTION** hazards involve equipment or property damage. Operation of damaged equipment can, under certain operational conditions, result in degraded process system performance that can lead to injury or death. Total compliance with all **DANGER**, **WARNING**, and **CAUTION** notices is required for safe operation.



This is the safety alert symbol. It alerts you to potential personal injury hazards. Obey all safety messages that follow this symbol to avoid possible injury or death.



Indicates a potentially hazardous situation which, if not avoided, could result in death or serious injury.



Indicates a potentially hazardous situation which, if not avoided, could result in serious injury.



Indicates a potentially hazardous situation which, if not avoided, could result in minor or moderate injury.



When used without the safety alert symbol, indicates a potentially hazardous situation which, if not avoided, could result in property damage.

Note: Indicates important facts and conditions.

About this Manual

- The information in this manual is subject to change without prior notice.
- The information contained in this manual, in whole or part, shall not be transcribed or copied without Baker Hughes's written permission.
- Please report any errors or questions about the information in this manual to your local supplier.
- These instructions are written specifically for the 35002 Series Camflex II, and do not apply for other valves outside of this product line.

Useful Period

The current estimated useful life period for the 35002 Series Camflex II is 25+ years. To maximize the useful life of the product, it is essential to conduct annual inspections, routine maintenance and ensure proper installation to avoid any unintended stresses on the product. The specific operating conditions will also impact the useful life of the product. Consult the factory for guidance on specific applications if required prior to installation.

Warranty

Items sold by Baker Hughes are warranted to be free from defects in materials and workmanship for a period of one year from the date of shipment provided said items are used according to Baker Hughes recommended usages. Baker Hughes reserves the right to discontinue manufacture of any product or change product materials, design or specifications without notice.

Note: Prior to installation:

- The valve must be installed, put into service and maintained by qualified and competent professionals who have undergone suitable training.
- All surrounding pipe lines must be thoroughly flushed to ensure all entrained debris has been removed from the system.
- Under certain operating conditions, the use of damaged equipment could cause a degradation of the performance of the system which may lead to personal injury or death.
- Changes to specifications, structure, and components used may not lead to the revision of this manual unless such changes affect the function and performance of the product.

1. Introduction

The following instructions are designed to assist maintenance personnel in performing most of the maintenance required on the Camflex II valve and if followed carefully will reduce maintenance time.

Baker Hughes has highly skilled Service Engineers available for start-up, maintenance and repair of our valves and component parts. In addition, regularly scheduled training programs are conducted to train customer service and instrumentation personnel in the operation, maintenance and application of our control valves and instruments. Arrangements for these services can be made through Baker Hughes products representative or district office. When performing maintenance use only Masoneilan replacement parts. Parts are obtainable through your local representative or district office. When ordering parts always include **MODEL** and **SERIAL NUMBER** of the unit being repaired.

2. General

These installation and maintenance instructions apply to 1" through 12" sizes (DN 25 through 300 sizes), all available

ratings, and pneumatic actuators. The model number, size and rating of the valve are shown on the serial plate. Refer to Figure 1 to identify the valve model.

3. Principle of Operation

The concept of the Camflex II valve is based on an eccentrically rotating spherical plug contained in a free flow body design. The plug seating surface is joined by flexible arms to a hub which slides onto a rotating shaft. The plug is free to center itself along the axis of the shaft. A positive seal between plug and seat is achieved by elastic deformation of the plug arms. The chamfered seat ring is fixed in the valve body by a threaded retainer.

The plug and shaft are rotated through an angle of 50° by a lever linked to a powerful spring-opposed rolling diaphragm actuator.

The solid disk-type handwheel and locking hex nut, optional, are mounted on the yoke, opposite the actuator and may be used to manually operate the valve or as a limit stop. A threaded hole in the opposite side of the yoke is plugged but can be equipped with an optional cap screw and locknut, which may be inserted as a limit stop in the other direction, or in combination with the handwheel to lock the valve in a selected position.

35002 Series Numbering System

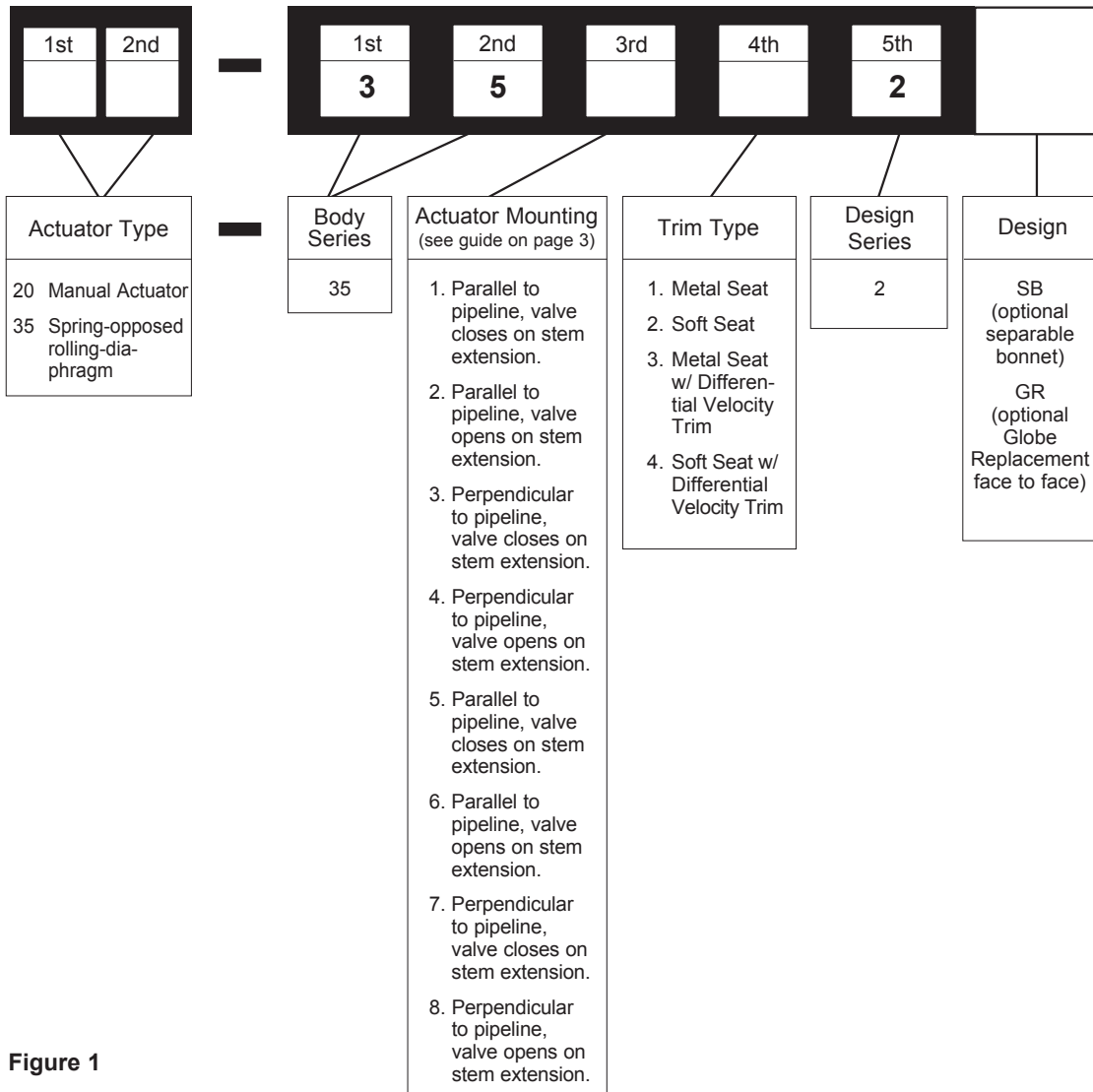

Figure 1

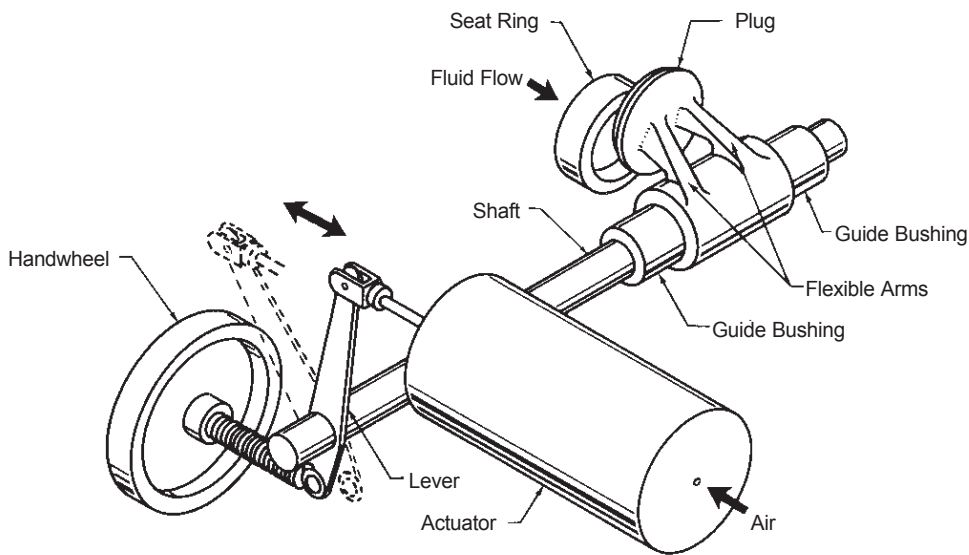

Figure 2

Note: The handwheel on Camflex II is designed to be used for emergency action only.

The actuator is generally mounted with air-loading to counter the dynamic torque on the plug. In Figure 2 the flow direction tends to open the plug and the actuator is oriented to close it with increasing air pressure. The actuator spring force assists plug off-balance forces to open the valve on air failure. If the valve is to close on air failure, the body would be turned around in the line so that flow tends to close the plug and the actuator position would be reversed.

The Camflex II valve has a modified linear flow characteristic, which is the same in either flow direction. It can be easily transformed to an equal percentage when equipping the valve with a positioner 4700 series, 8000 series or SVI Smart Valve Interface. Reduced TRIM factors 0.4 and 0.6 are available on all sizes. The flow capacity of a 0.4 factor is 40% of the nominal capacity of the valve and it is 60% for the 0.6 factor. Factors 0.1 and 0.2 are available on the 1" (DN 25) valve.

The ability of the Camflex II valve to handle a wide range of process fluid temperatures is due to the long integrally cast bonnet. This affords ample radiation surface to normalize the packing temperature. Therefore, with self-lubricating TFE Aramid fiber packing, the valve handles temperatures from -196°C to +400°C (-321°F to +752°F). When insulating the valve, do not insulate the valve bonnet (see Figure 3).

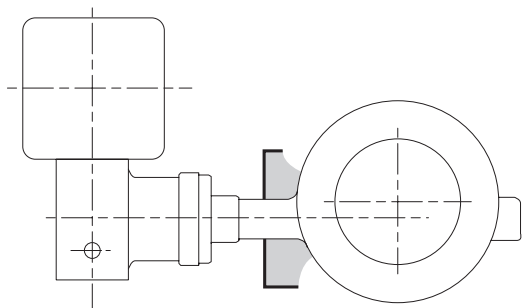

Figure 3

4. Unpacking

Care must be exercised when unpacking the valve to prevent damage to the accessories and component parts. Should any problems arise, contact your representative or district office.

Note: For ease of shipment and to prevent damage, valves equipped with the spring diaphragm actuator are shipped with the handwheel unassembled. Refer to Section 10.3 for handwheel assembly procedures.

5. Installation

The Camflex II valve has been assembled at the factory in accordance with specific instructions concerning flow direction and actuator mode. The valve must be installed so that the controlled substance will flow through the valve in the direction indicated by the flow arrow (25), which is located on the upper part of the valve bonnet. The valve actuator should be installed so the actuator is above the centerline of the shaft. To install the valve in the line, proceed as follows:

CAUTION

Any change in flow direction or actuator mode must be accomplished as outlined in Sections 7 and 10 of this instruction manual. Failure to follow these could result in personal injury and equipment malfunction.

- A. Check the model number on the serial plate (56) against the numbering System described in Figure 1 to determine the valve mode.
- B. Clean piping and valve of all foreign material such as welding chips, scale, oil, grease or dirt. Gasket surfaces should be thoroughly cleaned to ensure leak proof connections.
- C. To allow for in-line inspection, maintenance or removal of the valve without service interruption, provide a manually operated stop valve on each side of the Camflex II valve with a manually operated throttling valve mounted in the by-pass line.

Note: If a flanged Camflex II is being installed and the distance between flanges is established by ANSI or DIN, spool pieces (spacers) are inserted between the line flange and the valve body flange. Gaskets and valve bolting are then installed and torqued using standard flange and line bolting criteria.

- D. For flangeless valves, refer to Figure 23 and determine the correct size and quantity of bolts to be used for the valve and flange rating.
- E. If the valve is to be installed in a horizontal position, install the lower flange bolting to provide a cradle, which will help support the valve while installing the remaining bolts.
- F. Place the valve in the line.
- G. Select and install correct gaskets.

Note: Spiral wound gaskets, suitable for service conditions are recommended.

- H. Insert remaining flange bolting ensuring that the bolts align with the special bosses on the body, which assure the valve is centered in the line and also prevent rotation.

Note: For certain flange standards, through bolting is not possible because of the valve body neck or bonnet. To accommodate flange bolting, guide arms with threaded holes or slots are provided on the valve body to receive flange bolts (refer to Figure 22).

- I. Tighten flange bolts evenly and firmly.

CAUTION

If the valve is to be insulated, do not insulate the valve bonnet.

Note: If the valve is equipped with manual handwheel, it may now be placed in service.

6. Air Supply Piping

Air is supplied to the actuator through the 1/4" NPT tapped connection in the diaphragm case. Refer to Figure 14 to determine the correct supply pressure and tubing size, then connect air supply piping.

CAUTION

Do not exceed maximum air pressure indicated. Personal injury and equipment malfunction could result.

Note: When the valve is equipped with regulators or other accessories supplied by Baker Hughes, only connections to those accessories are required since the piping to the actuator is connected at the factory. Some valves equipped with electrical accessories will require appropriate wiring. Refer to manufacturer's instructions for correct wiring information.

7. Placing in Service

With the valve properly installed in the line and all air or electrical service connected, it is recommended that the valve be run through one cycle to ensure proper functioning. Proceed as follows:

- A. Back off the handwheel (53) so that it will not interfere with the operation of the valve and tighten the handwheel lock (52).

Note: If the valve is equipped with the optional limit stop (77), it should also be backed off to prevent interference with the operation of the valve.

- B. Apply correct air pressure to the actuator.

Note: Valve should function smoothly and with maximum pressure, the valve indicator (6) should show full open or full close depending on valve mode.

- C. Relieve air pressure and return valve to normal mode.
- D. Gradually open process lines to place the valve in service.
- E. Check for leaks. Repair as required.

CAUTION

Always ensure process pressure, air pressure and electrical service are off and the valve is isolated and relieved of pressure before performing maintenance on the valve.

- F. If desired, the handwheel may be used as a limit stop. Set in desired position and lock.
- G. If the optional limit stop (77) is used, set and tighten locknut.

8. Disassembly

8.1 Actuator Removal From Body S/A (Refer to Figures 16 and 17)

Maintenance required on the internal components of the valve or re-orientation of the actuator and body, requires that the actuator and yoke be removed from the valve. On the size 6, 7 and 9 actuators, for ease of handling and reassembly, it is recommended that the spring barrel be removed from the yoke and then the yoke separated from the valve body.

CAUTION

Prior to performing maintenance on the valve, isolate the valve, vent the process pressure and shut off supply and signal air lines to the actuator.

Note: If the valve will be reassembled in the same orientation, it is recommended that the body to yoke orientation and the actuator to yoke orientation be marked in relation to each other. This will simplify reassembly.

- A. If required, remove the valve from the line.
- B. Remove rear cover (29) and front cover (32) by removing the two cover screws (30).
- C. Remove bottom cover (11) and spring barrel boss cover (58).

- D. Remove the adjustable indicator (88) by removing the two screws (89).
- E. Loosen handwheel lock (52) and turn handwheel (53) so it does not interfere with the movement of the lever (34).

Note: On valves supplied with the optional limit stop, (Figure 17) loosen nut (78) and back off the limit stop screw (77) so it will not interfere with the movement of the lever (34).

- F. Connect an air line to the actuator supply port and using a manual loading panel or regulated air supply, apply enough air pressure to the actuator so the lever will move to an intermediate position.

CAUTION

Do not exceed pressure listed in Figure 14 for actuator used. Do not use handwheel to move the lever.

Note: If the valve is to be reassembled using the same orientation, it is recommended that the yoke (33) and lever (34) alignment, in the closed position, be marked to simplify reassembly and alignment of the lever and shaft to ensure proper valve functioning. See Figure 17.

- G. Remove clevis pin clips (5).
- H. Remove clevis pin (7).
- I. Relieve air pressure from actuator enabling clevis (35) to disengage from lever (34).

Note: If the valve is equipped with a positioner, refer to the appropriate positioner instruction for procedures on cam or lever removal. Then proceed to step K.

- J. Remove shaft cover (9) by removing cover screw (10).

CAUTION

Depending on the size and weight of the actuator. It is recommended that proper lift and support procedures be utilized when removing the spring barrel or yoke.

- K. Ensure spring barrel is properly supported.
- L. Loosen and remove cap screws (36) and lock washers (37), then remove spring barrel (38).
- M. Loosen lever capscrew (49).
- N. Loosen the stud nuts (94) and disengage the packing flange.
- O. Loosen the stud nuts (27) to separate the actuator from the body S/A.

Note: With body secure, grasp lever and yoke and separate. Yoke, lever and packing flange are removed at the same time. The yoke may have to be struck with a soft face mallet to break it loose.

8.2 Actuator Complete Disassembly

The spring diaphragm actuator used on the Camflex II valve was designed basically as a low cost non-replaceable item and

therefore disassembly is not recommended. However, in some instances and for emergency purposes, disassembly may be required. Proceed as follows.

- A. If the actuator is not removed from the body proceed to the paragraph 9.1 A. to 9.1 L.
- B. Loosen locknut (46) then remove the clevis (35) and the locknut (46).
- C. Loosen and remove capscrew (41) and remove dia-phragm case (42) and diaphragm (40).
- D. Using a deep socket, loosen and remove lock nut (45) and washer (44).
- E. Remove piston (43) and spring (39) and inspect all components.
- F. Proceed to section 10.2 for reassembly.

8.3 Valve Body (Refer to Figures 4 and 16)

Maintenance to the internal components required on the Camflex II Valve can normally be easily determined since the seat ring and plug can be seen once the valve is removed from the line. Although it may be determined that the seat ring does not need replacement, it must be noted that the new plug and seat ring must be lapped, thus requiring the disassembly of the body. It is recommended that both seat ring and plug be replaced if one or the other is damaged due to service.

After the actuator has been removed from the body, disassemble the valve using the following procedure:

CAUTION

Prior to performing maintenance on the valve, isolate the valve and vent the process pressure.

- A. For 35002 SB (Separable Bonnet) versions, remove bonnet nuts (104) and lift off bonnet (102) complete with packing (17) and packing follower (15) from the body as an assembly. Proceed to step D.
- B. Remove packing follower (15).
- C. Remove safety pin (16).

CAUTION

The purpose of the safety pin is to prevent the shaft from being pushed out if the yoke is removed while the valve is still pressurized. The internal components of the valve cannot be removed without first removing the safety pin.

- D. Pull on the shaft (19) to remove it.

Note: Difficulty is sometimes encountered when removing the shaft from the plug mainly due to an excessive accumulation of deposits between the plug splines and the shaft. Application of heat to the plug shaft bore while using one of the following methods will facilitate removal.

CAUTION

When using heating devices, ensure that proper safety practices are observed. Such items as the flammability and toxicity of the controlled substance must be considered and proper precautions taken.

If the shaft is not removed easily, replace the lever (34) on the splined end of the shaft (19), tighten the lever capscrew (49) and using a mallet, tap the lever (34) as close to the shaft as possible and remove the shaft (19).

Note: If the shaft cannot be removed by tapping the tightened lever, Figure 20 illustrates an alternative method of removal. Using a pipe nipple of suitable size and length and reversing the packing flange and stud nuts as shown, the shaft may be jacked out of the body. For larger valves, the use of an additional washer and nipple to assist in holding the tightened lever is recommended. The lever should be tightened at a point where the hub on the lever is flush with the end of the spline.

- E. The components which should come out with the shaft (19) are: the packing (17), packing box ring (23 or 100), spacer tube (20) and upper guide bushing (21).

Note: The spacer tube (20) and upper guide bushing (21) may remain in the body. They should be removed. The spacer tube (20) can only be removed by pulling it out the bonnet end of the body. The upper guide bushing (21) may be pushed through the body after removing the plug or pulled through the bonnet end of the body. On valves designed for use on slurry or viscous service, the upper guide bushing has an inner "O" ring (92) and an outer "O" ring (93) and the lower guide bushing has inner "O" ring (95) and outer "O" ring (96) (Refer to Figure 4).

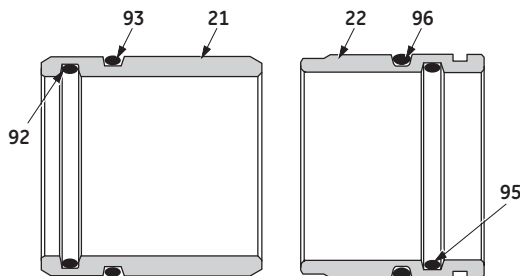

Figure 4 - Optional "O" ring arrangement

- F. Remove the plug (4) through the end of the body opposite the seat ring.
- G. Remove the lower guide bushing (22).

Note: A groove is provided in the bushing for prying out the bushing using a screwdriver. If the bushing will be pried out it should be pried from two sides to prevent jamming the bushing during removal. If the bushing does not come out easily, fill the bushing with grease, insert the shaft (19) into the valve insuring that the machined portion of the shaft starts into the lower guide bushing. Using a soft faced mallet, strike the end of the shaft lightly until the bushing is pushed out partially. Remove the shaft and complete removal of the bushing by prying out using the groove provided.

CAUTION

Do not pry the bushing using the seat for leverage. If the bushing cannot be easily removed, proceed to section 8.3.1 and remove the seat ring retainer and seat ring then remove the bushing. Place a piece of soft stock (brass, etc.) between the inner seat shoulder and prying device to prevent damage to the seat sealing area of the body.

8.3.1 Seat Ring Removal (Refer to Figure 16)

The following procedures outline the recommended method for removing the seat ring retainer (3) with the use of retainer wrenches. Baker Hughes manufactures and has available, for a nominal price, seat ring retainer wrenches for the Camflex II, 1" through 4" (DN 25 through 100) sizes. It is highly recommended that wrenches be purchased or fabricated to facilitate removal and reassembly of the seat ring (2) since SPECIFIC TORQUES MUST BE ACHIEVED to obtain tight shutoff and ensure proper functioning of the valve.

Figure 5 shows the recommended materials, thickness and method of construction along with specific dimensions to facilitate construction.

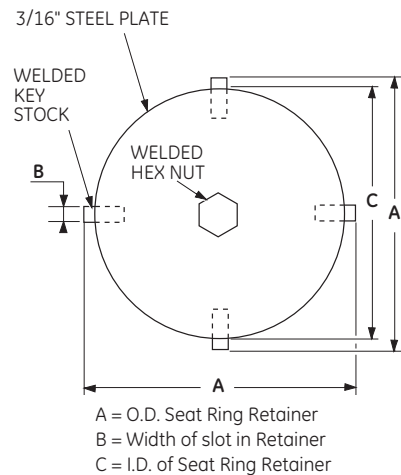

Figure 5

- A. Secure the valve body in a vise or appropriate holding device with the seat ring facing up.

CAUTION

Care must be taken to avoid damage to the gasket face on the valve body.

- B. Place retainer wrench so it engages retainer lugs.
- C. Engage the retainer wrench with an impact wrench or suitable wrench and loosen, then remove retainer (3) by turning counterclockwise.

Note: The Camflex GR body constructions will require an extension to reach the retainer, due to the longer body pattern.

- D. Lift out seat ring.

Note: In an emergency, drifts may be used to remove the seat ring retainer. However, two drifts should be used and placed in the slots 180° apart and struck simultaneously.

8.3.2 DVD Removal (Refer to Figure 16)

In case of Camflex with the DVD option, model number 35x3x or 35x4x, the DVD is installed in the body, it is recommended to use the DVD wrenches to remove this device (105). Baker Hughes manufactures and has available, for a nominal price, DVD wrenches for the Camflex II, 1" through 12" sizes (DN 25 through 300 sizes). It is highly recommended that wrenches be purchased or fabricated to facilitate removal and reassembly of the DVD (105) since SPECIFIC TORQUES MUST BE ACHIEVED to ensure proper clamping of this DVD plate.

Figure 6 shows the recommended thickness and method of construction along with specific dimensions to facilitate construction.

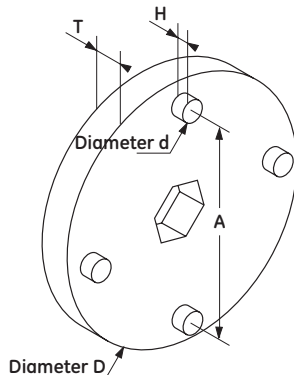

Valve Size	A inches (mm)	d inches (mm)	D inches (mm)	H inches (mm)	T inches (mm)
1" (DN 25)	1.063 (27)	0.142 (3.6)	1.236 (31.4)	0.079 (2)	0.4 (10)
1½" (DN 40)	1.496 (38)	0.157 (4)	1.772 (45)	0.118 (3)	0.5 (12)
2" (DN 50)	1.929 (49)	0.157 (4)	2.205 (56)	0.118 (3)	0.7 (18)
3" (DN 80)	2.913 (74)	0.177 (4.5)	3.248 (82.5)	0.157 (4)	0.8 (20)
4" (DN 100)	3.858 (98)	0.197 (5)	4.213 (107)	0.275 (7)	0.8 (20)
6" (DN 150)	5.905 (150)	0.236 (6)	6.260 (159)	0.354 (9)	1.0 (25)
8" (DN 200)	7.913 (201)	0.236 (6)	8.268 (210)	0.394 (10)	1.0 (25)
10" (DN 250)	9.843 (250)	0.236 (6)	10.315 (262)	0.394 (10)	1.2 (30)
12" (DN 300)	11.732 (298)	0.276 (7)	12.204 (310)	0.472 (12)	1.2 (30)

Figure 6

- A. Secure the valve body in a vise or appropriate holding device with the plug side facing up (refer to Figure 16).

CAUTION

Care must be taken to avoid damage to the gasket face on the valve body.

- B. Place DVD plate wrench so it engages retainer lugs.
 C. Engage the retainer wrench with an impact wrench or suitable wrench and loosen, then remove DVD (105) by turning counter-clockwise.

9. Maintenance

9.1 Diaphragm Replacement (Refer to Figures 16 and 17)

The recommended maintenance to be performed on the Camflex II Spring Diaphragm Actuator is limited to the replacement of the diaphragm (40). Removal of the actuator from the valve is not required. To replace the diaphragm, proceed as follows:

CAUTION

The valve must be isolated and free from any service pressure. All electrical or air pressure to component parts must be off. Pressure to actuator must be relieved.

Handwheel (53) and limit stop (77) must be backed off to allow free travel of the lever (34).

- A. Bypass the valve, shut off stop valves and isolate valve in compliance with CAUTION note listed above.
 B. Shut off and disconnect air supply tubing to the actuator.
 C. Remove the four capscrews (41) from diaphragm case (42) and remove diaphragm case.
 D. Remove diaphragm (40).
Note: Diaphragm is glued to the top of the piston (43).
 E. Remove tape or glue from the top of the piston and clean thoroughly.
 F. Clean diaphragm case (42) and spring barrel (38) at the area that engages the diaphragm bead in preparation for reassembly.

Note: To hold the diaphragm in place on the piston, an adhesive disc (adhesive both sides) or rubber cement is used. If rubber cement is used, it should be applied to both the piston and the diaphragm or in accordance with the manufacturer's directions for the adhesive used. For recommended adhesives see Figure 15.

For the diaphragm replacement, use one of the two following methods:

Method 1: Points G-1 / H-1 / I-1 / J-1 / K-1

- G-1. Apply adhesive tape or cement to the top of the piston.
 H-1. The inscription "Piston Side" is located on the diaphragm (40). If used, apply cement to this side of the diaphragm.

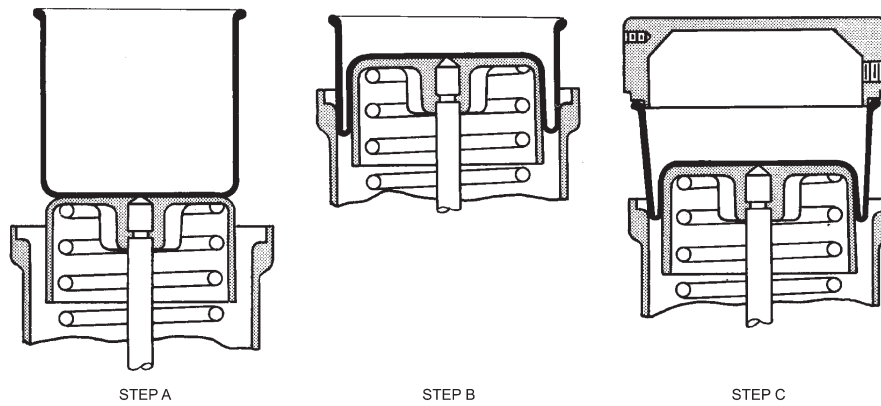

Figure 7 - Method 1

- I-1. Center and adhere diaphragm (40) to the top of the piston (43) (see Figure 7-Method 1, Step A).
- J-1. Roll the diaphragm (40) inside the spring barrel (38) until the diaphragm is partially engaged in the spring barrel (see Figure 7-Method 1, Step B).

CAUTION

Ensure that the capscrew holes in the diaphragm case and spring barrel are aligned to prevent twisting of the diaphragm in aligning the holes. The diaphragm case (42) is normally assembled with the air inlet port placed on the bottom side of the actuator. Depending on the desired location, it can be placed in any desired position around the spring barrel which allows the capscrew holes to line up. However, the drain hole in the spring barrel must always be facing down to allow for draining of any moisture which may enter the spring barrel cylinder (38). If the valve is equipped with the optional purge line, that line is inserted into the drain hole.

- K-1. Place the bead of the diaphragm (40) over the diaphragm case lip (42) and carefully slide the diaphragm case (42) down over the piston (43) until it seats on spring barrel (38). (see Figure 7-Method 1, Step C).

For next step, go to Point L.

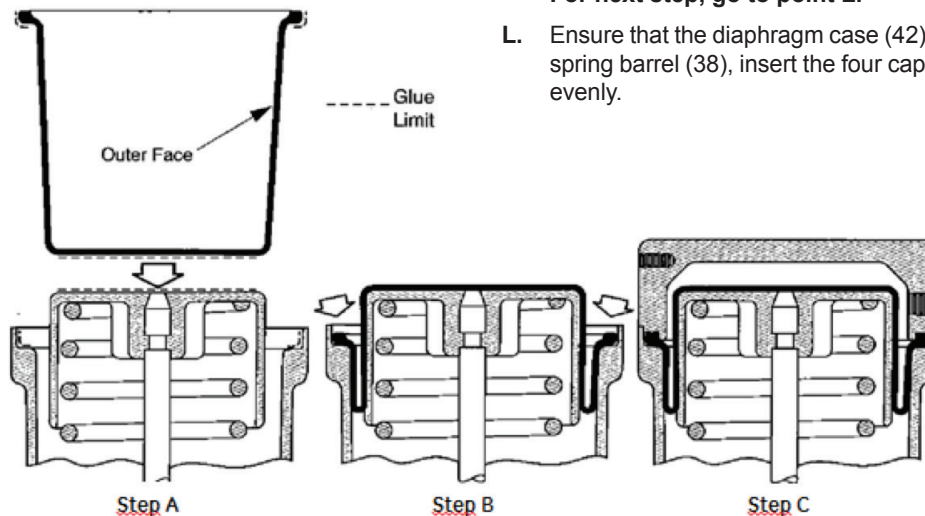

Figure 7 - Method 2

Method 2: Points G-2 / H-2 / I-2 / J-2 / K-2

- G-2. Apply coating of Neoprene glue (or similar) on the bead and on the inner face of the diaphragm (40), on the piston (43) and in the spring barrel lip (38).

Note: The inner face of the diaphragm in contact with the piston is marked with the inscription "piston side"; be careful to keep coating of the Neoprene with limits corresponding to the flat part of the piston (Figure 7-Method 2, Step A).

- H-2. Center and adhere the diaphragm (40) on the piston (43) (Figure 7- Method 2, Step A).
- I-2. Roll the diaphragm (40) carefully inside the spring barrel (38) until the bead engages the spring barrel groove (38). Press lightly and evenly the bead so as to get with the two Neoprene-coated part stuck together. Check there is no twisting of diaphragm inside the spring barrel (Figure 7-Method 2, Step B).
- J-2. Adjust diaphragm case (42) to the spring barrel (38) after checking that air connection is on the correct side and the threaded holes of diaphragm case (42) and the holes of the spring barrel (38) line up.

Note: Tapped air connection should be in line with the vent hole in spring barrel (38).

- K-2. Clamp the bead of the diaphragm (40) between lips of diaphragm case (42) and spring barrel (Figure 7- Method 2, Step C).

For next step, go to point L.

- L. Ensure that the diaphragm case (42) is evenly seated on the spring barrel (38), insert the four capscrews (41) and tighten evenly.

- M. Connect air supply line to diaphragm case (42).
- N. Turn on air supply and check for leaks.
- O. If necessary, reposition handwheel (53) and limit stop (77), (optional) to desired location and place valve back in service.

9.2 Body S/A Internal Parts

During a maintenance of Camflex II valve it is necessary to inspect all the internal parts to determine if they are worn, corroded and damaged, especially the following seating area:

- body and seat ring contact area.
- the seating surface of the plug and seat ring.
- the guide surface of the shaft and the guide bushing.

All parts which are damaged must be replaced by original spare parts.

9.2.1 Hard Seat Lapping

Lapping is the process of working the valve sealing parts against each other with an abrasive, to produce a close fit. To perform the lapping operation, proceed as follows.

- A. Clean the seat ring sealing surface in the valve body and the seat ring shoulder.
- B. Apply a small amount of fine grinding compound to the seat ring shoulder.

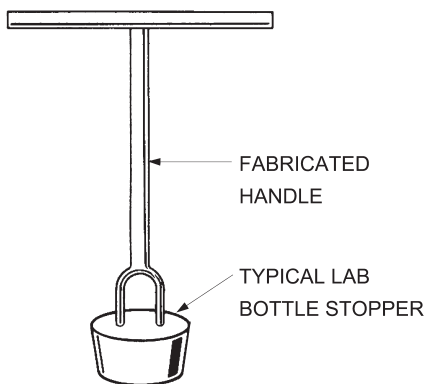

Figure 8

- C. Insert the seat ring into the body and lap lightly by rotating the seat ring in the body, ensuring that the entire seat ring sealing surface in the valve body is lapped. Do not rotate in one place.

Note: Figure 8 illustrates a simple tool which may be fabricated to facilitate this lapping operation on smaller valves.

- D. Remove seat ring and clean thoroughly.
- E. Place seat ring on a flat surface with the seating area facing up.
- F. Apply a small amount of fine grinding compound to the seat ring seating surface.
- G. Lap the plug lightly against the seat ring while turning and oscillating the plug in all directions.
- H. Clean seat ring, plug and valve body thoroughly in preparation for reassembly.

9.2.2 Soft Seat

Do not lap the soft seat ring to the plug; however, the seat ring must be lapped to the valve body. The procedure for lapping the seat ring to the body is the same as stated in items A through D of Section 9.2.1 on Hard Seats.

9.3 Yoke Assembly (Refer to Figures 16 and 17)

Maintenance required on the yoke (33) is limited to replacement of the grommet (12) and the shaft bearing (8). To replace either, the actuator must be separated from the body. (Depending on the type of actuator used, refer to appropriate section). Insert the grommet into the yoke with the recessed part of the grommet towards the shaft bearing. The shaft bearing (8) is slip fit into the yoke and is removed by pushing it out towards the grommet.

CAUTION

Ensure the bearing seat in the yoke is clean. The bearing should slide in easily. Do not use excessive force to push bearing in.

10. Reassembly Procedures

10.1 Spring Diaphragm Actuator

When the actuator has been disassembled using Section 8.2 to reassemble the actuator, proceed as follows:

- A. Replace spring (39) in piston (43).
- B. Replace washer (44) and locknut (45).
Note: Locknut (45) must be threaded the full length of the threads.
- C. To reassemble the diaphragm and upper diaphragm case, refer to Section 9.1, steps E. through L.
- D. Replace locknut (46) and clevis (35).
- E. Determine correct orientation and replace actuator on yoke and replace lockwashers (37), capscrews (36) and tighten firmly.
- F. Refer to Section 11. for actuator stem adjustment.

10.2 Spring Diaphragm Actuator on Body S/A (Refer to Figures 16 and 17)

After completing the required maintenance or changing valve, actuator and yoke assembly, reassemble using the following procedure:

- A. Determine correct valve to actuator orientation.
- B. If required, reposition body studs (28) and packing flange studs (13).

Note: Depending on the actuator position, ensure that the body studs (short studs) when placed through the yoke holes will be positioned in the front of the yoke opening for ease of accessibility.

- C. Ensure that grommet (12) and shaft bearing (8) are in the yoke. Turn shaft so the plug is in the closed position.

- D. Slide the valve shaft partly into the lower yoke opening, allowing enough room to place packing flange (14) over the shaft (19).

Note: Packing flange (14) is placed on the shaft (19) with the concave side toward the valve packing (17).

- E. Ensure slots in packing flange (14) line up with packing flange studs (13).
- F. With packing flange on the shaft, continue sliding the valve shaft toward the yoke (33) and through the grommet (12) in the yoke (33).
- G. Place the lever (34) in the yoke and in line with the shaft so the boss on one side of the lever shaft hole is toward the shaft bearing (8) and engage the shaft to the lever splines.

Note: Shaft must engage lever so the indicator dot on the clevis pin, when placed in the lever hole, shows the valve closed. Temporarily place clevis pin into lever (34) and check indicator dot alignment. Dot should just start touching the closed indicator line on the front cover (32) (Refer to Figure 18). If the orientation is not changed, align lever and mark on yoke then check alignment. (Refer to Figure 17).

CAUTION

Do not use air pressure to check alignment, since during normal operation and with full air pressure, the indicator may overshoot the closed indicator mark on the cover. This is acceptable.

- H. Slide shaft completely through lever to engage shaft bearing (8). Yoke should now be fully seated on the valve bonnet flange.
- I. Replace and tighten body stud nuts (27).
- J. Replace packing flange stud nuts (94) and finger tighten only.
- K. Slide the lever (34) on the shaft (19) toward the valve and tighten lever capscrew (49).
- L. Pull the lever and shaft toward the bearing (8) in the yoke.

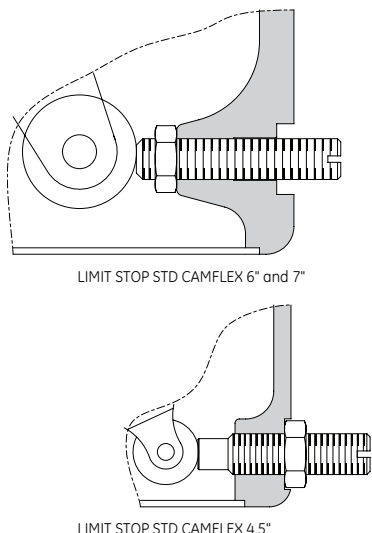

Figure 9

CAUTION

This is required to ensure the shaft (19) is shouldered on the shaft bearing (8) and to ensure free operation of the valve.

- M. Loosen lever capscrew (49) and slide lever (34) so it will shoulder against the shaft bearing (8) and tighten capscrew (49).

Note: if the actuator cylinder (38) has been removed proceed to step N. If it has not, proceed to Section 11, Actuator Stem Adjustment.
- N. Determine the desired actuator action and replace actuator cylinder (38) on the yoke (33) and secure in place with four capscrews (36) and lockwashers (37).
- O. Proceed to Section 11, Actuator Stem Adjustment.

10.3 Handwheel Reassembly

- A. Place the valve so the position cover (11) is up.
- B. Remove Truac ring (50) and handwheel washer (51) from the handwheel powerscrew.
- C. Insert handwheel powerscrew with lock (52) in place into the appropriate hole in the yoke and screw in clockwise.
- D. Replace the washer (51) and Truac ring (50)
- E. Back off handwheel lightly against washer and lock in the off position with lock (52).
- F. Replace bottom cover (11) by snapping in place.

Note: To use the handwheel, loosen the lock (52) and turn. The handwheel can be used as a limit stop on the valve by locking it in any position.

10.4 Limit Stop Reassembly

Two different types of assembly for the limit stop in function of the actuator size: see Figure 9.

10.5 Valve Body Reassembly (Refer to Figure 16)

Prior to reassembly, the valve body should be thoroughly cleaned and the seat ring and plug may be lapped as indicated in Section 9.2. Upon completion of the above, proceed as follows:

CAUTION

Lubricants and sealers are required during reassembly. Figure 15 identifies recommended products for certain service conditions. Ensure that any lubricant used is compatible with service conditions.

- A. Apply a small amount of thread lubricant to the seat ring retainer threads and install seat ring retainer (3) and hand tighten only.

CAUTION

Do not tighten the seat ring retainer to torque specification at this time.

- B. Place valve body (1) on flat surface so that the seat is down.
- C. Coat lower guide bushing (22) with recommended lubricant and insert into the body.

Note: Groove in the guide bushing (22) must be towards the body center. Refer to Figure 10 for correct assembly sequence. If the shaft (19) is the previous design it may have a circular groove, if so, install the retaining ring (18).

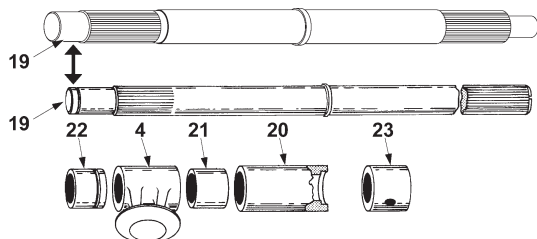

Figure 10

- D. Coat the upper guide bushing (21) spacer tube (20) and the shaft splines (plug side) with recommended lubricant.
- E. Insert the spacer tube (20) over the lubricated part of the shaft.

CAUTION

When a recessed groove exists in the spacer tube (20), this spacer tube (20) must be placed on the shaft (19) so that the shaft shoulder or retaining ring fits into the recessed groove on one end of the spacer tube (20).

- F. Place upper guide bushing (21) on the shaft (19).
- G. Place plug (4) in body so it rests on the seat.
- H. Insert the shaft sub-assembly into the body (1) and engage plug (4) and lower guide bushing (22).

Note: The shaft (19) should be inserted into the plug so that when the plug is seated, the slot at the outer end of the shaft is perpendicular to the flow through the valve.

In case of 35002 SB, separable bonnet version, follow the operations described from N to U.

- I. Install the packing box ring (23), bevel side out, over the shaft (19) and into the valve bonnet being sure that the hole in the ring is aligned with the threaded port in the bonnet.
- J. Apply a suitable lubricant to the threads of the safety pin (16) and screw into the body neck and tighten.

CAUTION

The Safety Pin is a safety device which must not be replaced by a plug. Use only genuine supplied safety pins. Pin must engage hole in packing box ring (23). Test by manually pulling on the shaft to verify engagement.

- K. Install packing (17) insuring that the skive cut of each piece of packing is offset approximately 120° from that of the adjacent piece of packing.

Note: Sizes 1" thru 3" (DN 25 through 80) use 7 pieces of packing; sizes 4" thru 12" (DN 100 through 300) use 6 pieces of packing.

- L. Install packing follower (15) rounded, bevel side out.
- M. Proceed to Section 10.6 on seat ring alignment.
N through U apply to separable bonnet design only:
- N. If necessary, install the studs (103) in the bonnet (102).
- O. Install the stop ring (100).
- P. Place the gasket (101) in the groove of the bonnet. The old gasket (101) must not be re-used.
- Q. Place the bonnet with the studs on the body and screw the nuts (104).
- R. Tighten the nuts (104) according the table of Figure 11.

Valve Size	Torque lb.ft	Torque m.N
1" (DN 25)	22	30
1½" (DN 40)		
2" (DN 50)		
3" (DN 80)	55	75
4" (DN 100)	55	75
6" (DN 150)	107	145

Figure 11

Note: It is important to tighten the nuts step by step, during the tightening the bonnet flange must keep the shaft axis aligned.

- S. Install packing (17) insuring that the skive cut of each piece of packing is offset approximately 120° from that of the adjacent piece of packing.

Note: Sizes 1" through 3" (DN 25 through 80) use 7 pieces of packing; sizes 4" through 12" (DN 100 through 300) use 6 pieces of packing.

- T. Install packing follower (15) rounded, bevel side out.
- U. Proceed to Section 10.6 on seat ring alignment.

10.6 Seat Ring Alignment

Aligning the seat ring (2) and plug (4) is required whenever the seat ring or plug have been replaced or disassembled. Proceed as follows:

- A. Place valve on flat surface with retainer (3) and seat ring (2) facing up.

Note: The casting marks (=) indicate the seat ring end of the body.

- B. Remove the retainer ring (3) and the seat ring (2).
- C. Apply a thin coat of sealant to the seat ring shoulder that engages the body and replace seat ring (2).
- D. Apply a small amount of thread lubricant to the seat ring retainer threads and install seat ring retainer (3) and hand tighten only.

CAUTION

Do not tighten the seat ring retainer to torque specification at this time.

- E. Replace lever (34) on valve shaft (19) and tighten lever capscrew (49).
- F. Using the lever (34) manually close the plug with sufficient force to allow seat ring and plug to align.
- G. Using the seat ring wrench, tighten seat ring retainer to the minimum torque value specified in Figure 12.

Note: In some cases, for the valves from 3" to 12" (DN 80 to 300) with metal seat, the alignment can be improved by placing a piece of paper 0.10mm (0.004") thick and approximately 6mm (1/4") wide at a point where the leading edge and the trailing edge of the plug contacts the seat ring and close the plug. With a slight pressure on the lever, the paper strips should both be clamped in place. For the valve 8" to 12" (DN 200 to 300), the piece of paper shall be 0.20mm (0.008") thick and 12mm (1/4") wide.

Valve Size	Minimum Torque	
	lb.ft	m.N
1" (DN 25)	60	81
1½" (DN 40)	95	130
2" (DN 50)	100	135
3" (DN 80)	290	395
4" (DN 100)	363	490
6" (DN 150)	825	1120
8" (DN 200)	975	1320
10" (DN 250)	1350	1830
12" (DN 300)	2250	3050

Figure 12

- H. Proceed to section on body to actuator assembly.

10.7 DVD Plate Reassembly

Using the same method and tooling as described in 8.3.2, tighten the Lo-dB™ plate at the indicated torque given in the table of Figure 13.

Valve Size	Tightening Torque	
	lb.ft	m.N
1" (DN 25)	74	100
1½" (DN 40)	81	110
2" (DN 50)	100	135
3" (DN 80)	220	295
4" (DN 100)	363	490
6" (DN 150)	780	1050
8" (DN 200)	975	1320
10" (DN 250)	1320	1830
12" (DN 300)	2250	3050

Figure 13

11. Actuator Stem Adjustment (Refer to Figures 16 and 17)

The following procedures must be adhered to in order to ensure correct valve operation. Failure to do so could result in valve damage and equipment malfunction.

CAUTION

Correct actuator stem adjustment is imperative for proper valve functioning. With the actuator assembled to the valve in the desired location and orientation proceed as follows:

Note: If any of the following steps were completed during maintenance or reorientation of actuator to valve, proceed to the next step.

- A. Remove front cover (32) and rear cover (29) by removing the two-cover screws (30).
- B. Back off handwheel (53) so it does not interfere with the operation of the lever (34).
- C. If applicable, back off optional limit stop (77) so it will not interfere with the operation of the lever (34).
- D. Apply air pressure to the actuator and move lever (34) to an intermediate position.

CAUTION

Do not exceed pressure listed in Figure 14 for the actuator used. Do not use handwheel (53) to move lever (34).

- E. Remove adjustable indicator (88) by removing the two screws (89).
- F. Remove clevis pin clip (5), remove clevis pin (7).
- G. Relieve air pressure to the actuator to allow the clevis (35) and lever (34) to separate.

Note: If the unit is air-to-open, separate clevis (35) and lever (34) then loosen clevis locknut (46) and remove clevis.
- H. Insert clevis pin (7) back in lever (34).
- I. Manually push the lever (34) so the valve is in the closed position.
- J. Temporarily replace front cover (32) and check the location of the clevis pin (7) in relation to the closed position indicator mark on front cover (32).

CAUTION

The relationship must be as shown in Figure 18. If it is not, the yoke must be separated from the body and the lever (34) repositioned on the shaft. Refer to appropriate section. Failure to comply could result in the valve short stroking or over stroking and could damage the valve.

Note: If the unit is air-to-open, replace clevis locknut

(46) and clevis (35).

- K. Proceed to one of the following sections for final adjustment. Air-to-Open, Section (K-1), Air-to-Close Section (K-2).

K-1. Air-to-Open

After completing step A through J of Section 11, proceed as follows:

- A. Scribe a line on the clevis (35) in line with the inside of the yoke.
- B. Connect a regulated air supply directly to the actuator and gradually apply 8 psig (.55 barg) for size 9 actuators and 7 psig (.48 barg) for the others.
- C. The clevis should move approximately 1/4".
- D. With the lever and valve plug in the fully CLOSED position, the holes in the clevis (35) and lever (34) should be in line.

Note: If holes are in line proceed to Step J. If not in line, continue to next step.

- E. Move lever (34) to full open position.
- F. Gradually apply sufficient air pressure to extend clevis locknut (46) to an accessible position.

CAUTION

Do not exceed pressure listed in Figure 14 for the actuator used.

- G. Loosen clevis locknut (46).
- H. Reduce air pressure to actuator to 7 psig.
- I. Screw clevis (35) in or out on actuator stem so that the holes in the clevis (35) and lever (34) are aligned with the lever and plug in the fully closed position.
- J. Insert clevis pin (7) so indicator dot is visible through front cover (32) and secure with clevis pin clips (5).

Note: On the size 6 and 7 actuators, without the adjustable indicator (88), the clevis pin (7) must be installed so it protrudes toward the front cover (32). If the indicator dot is damaged, paint may be applied to the end facing the front cover (32) to make it more visible.

- K. Gradually apply sufficient air pressure to extend clevis locknut (46) to an accessible position and tighten firmly.

CAUTION

Do not exceed pressure listed in Figure 14 for the actuator used.

- L. Relieve air pressure.
- M. If used, replace adjustable indicator (88) to lever (34) with screws (89).

Note: If required, adjust indicator to front cover indicator marks.

- N. Replace front cover (32) and rear cover (29) and secure

in place with cover screws (30).

- O. Replace spring barrel boss cover (58) and bottom cover (11) (Snap fit).

Note: Prior to placing the valve in service, operate the valve actuator through one complete cycle to ensure proper functioning.

- P. If desired, set handwheel (53) or optional limit stop (77) to desired position.

K-1. Air-to-Close

After completing step A through J of Section 11, proceed as follows:

- A. Manually push lever (34) to the full CLOSED position.
- B. Connect a regulated air supply to the actuator.
- C. Gradually apply the final air pressure corresponding to the closed position. See value on the serial plate.
- D. With the lever (34) and valve plug in the CLOSED position, the holes in the clevis (35) and lever (34) should be in line.

Note: If holes are in line proceed to Step H, if not in line, continue to the next step.

- E. Release air pressure so clevis (35) will separate from lever (34).
- F. Loosen clevis locknut (46).
- G. Screw clevis (35) in or out so that when the air pressure corresponding to the closed position mentioned in C above is applied, clevis holes and lever will be in line.
- H. Insert clevis pin (7) so indicator dot is visible through front cover (32) and secure with clevis pin clips (5).

Note: On the size 6 and 7 actuators, without the adjustable indicator (88), the clevis pin (7) must be installed so it protrudes toward the front cover (32). If the indicator dot is damaged, paint may be applied to the end of the clevis pin (7) facing the front cover (32) to make it more visible.

- I. Tighten clevis locknut (46).
- J. Relieve air pressure to actuator.
- K. If used, replace adjustable indicator (88) to lever (34) with screws (89).

Note: If required, adjust indicator (88) to front cover (32) indicator marks with the valve in the closed position.

- L. Replace front cover (32) and rear cover (29) and secure in place with cover screws (30).
- M. Replace spring barrel boss cover (58) and bottom cover (11) (Snap fit).

Note: Prior to placing the valve in service, operate the valve actuator through one complete cycle to ensure proper functioning.

- N. If desired, set handwheel (53) or optional limit stop (77) to desired position.

12. Changing Body Position

CAUTION

Before any change in flow direction or actuator mode is made, the valve and actuator must be resized using current process conditions. Any change in the flow direction or actuator mode must be accomplished as outlined in this instruction, otherwise equipment malfunction could result.

Changing service requirements or service conditions may require a change in flow direction through the Camflex II valve. Figure 19 illustrates the various positions and flow directions in which the valve may be placed to accommodate requirements.

CAUTION

Changing the body position and flow direction could also require relocating the actuator. Ensure that the actuator location and action are in accordance with the recommended positions and modes illustrated in Figure 19. Illustrations are shown looking at the body through the bonnet with the actuator in front of the valve. The plug shaft is always rotated in a clockwise direction by the actuator to open the valve.

To change body position proceed as follows:

- A. Refer to Figure 19 and determine which is the desired valve position, flow direction and which actuator position is required.
- B. Proceed to the appropriate section of this instruction for the required disassembly and assembly procedures.

13. Changing Actuator Action

CAUTION

Before any change in flow direction or actuator mode is made, the valve and actuator must be resized using current process conditions. Any change in the flow direction or actuator mode must be accomplished as outlined in this instruction, otherwise equipment malfunction could result.

- A. Remove front cover (32) and rear cover (29) by removing the two cover screws (30).
- B. Remove spring barrel boss cover (58) (Snap fit).
- C. Remove bottom cover (11) (Snap fit).
- D. Using a manual loading panel, apply sufficient air pressure to the actuator to move the lever (34) to an intermediate position.

CAUTION

Do not exceed pressure listed in Figure 14 for actuator used. Do not use handwheel to move lever.

- E. Remove clevis pin clips (5) and remove clevis pin (7).
- F. Position lever so it does not contact handwheel power-screw assembly.
- G. Remove Truarc ring (50) and washer (51) from handwheel powerscrew assembly.
- H. Unscrew and remove handwheel powerscrew assembly from yoke (33).

Valve Size	Actuator Size Diameter	Maximum Air Supply				Recommended Tubing	
		A 564 Gr 630 Shaft		Austenitic Stainless Steel Shaft			
	inches (mm)	kPa	Psi	kPa	Psi	mm	inches
1" (DN 25)	4 1/2 (114)	138	20	138	20	4x6	1/4"
1 1/2" (DN 40)	4 1/2 (114)	172	25	172	25	4x6	1/4"
2" (DN 50)	4 1/2 (114)	207	30	207	30	4x6	1/4"
3" (DN 80)	6 (152)	207	30	207	30	4x6	1/4"
4" (DN 100)	6 (152)	310	45	310	45	4x6	1/4"
6" (DN 150)	7 (177)	448	65	310	45	4x6	1/4"
8" (DN 200)	7 (177)	517	75	379	55	4x6	1/4"
10" (DN 250)	7 (177)	517	75	448	65	4x6	1/4"
12" (DN 300)	7 (177)	517	75	517	75	4x6	1/4"
6" (DN 150)	9 (228)	344	50	276	40	4x6	1/4"
8" (DN 200)	9 (228)	344	50	276	40	4x6	1/4"
10" (DN 250)	9 (228)	448	65	310	45	4x6	1/4"
12" (DN 300)	9 (228)	517	75	379	55	4x6	1/4"

Figure 14

Service	Sealant	Lubricant	Diaphragm Glue
Condensate and Steam	Silver Seal T-J, Turbo 50 or HYLO-MAR SQ 32	Molykote G or GRAPHENE 702	3M High Track adhesive transfer tape (or equal)
Cryogenic -20°F to -320°F (-29°C to -196°C)	Crown N. 9008 Teflon Spray or RODORSIL CAF 730	Crown N. 9008 Teflon Spray or GRAPHENE 702	3M Pressure sensitive tape, double coated (or equal)
Oxygen	Drilube type 822 or BONNAFLON S/9	Drilube type 822 or OXIGNENOEX FF250	Eastman 910 Cement (or equal)
All Others ⁽¹⁾	John Crane Plastic lead N.2 HYLOMAR SQ 32	Molykote G or GRAPHENE 702	Goodyear Plibond Cement (or equal)

(1) Except Food Services.

Figure 15

- I. Remove handwheel thread plug (48).

Note: If the actuator is equipped with the optional limit stop (77), in place of the handwheel thread plug, it must be removed.

CAUTION

Depending on the size and weight of the actuator, it is recommended that proper lift and support procedures be utilized when removing the spring barrel or yoke.

- J. Ensure spring barrel is properly supported.
- K. Loosen and remove capscrews (36) and lockwashers (37) then remove spring barrel (38).

CAUTION

If the orientation of the actuator to valve requires that the yoke be rotated about the valve, it is recommended that Section 12 on changing yoke position be accomplished before proceeding.

- L. With the yoke assembled to the valve in the required orientation, place spring barrel (38) on desired yoke location and secure with capscrews (36) and lockwashers (37), and tighten firmly.
- M. Screw in handwheel powerscrew assembly into the powerscrew hole of the yoke which is on the opposite side of the spring diaphragm actuator.

Note: Handwheel action is always the same as air action and opposes the spring.

- N. Replace handwheel washer (51) and Truarc ring (50) and back off handwheel so the powerscrew will not interfere with the operation of the lever.

- O. Replace handwheel thread plug (48).

Note: If the valve is equipped with the optional limit stop (77) instead of the thread plug, it must now be installed, but ensure it is backed off as not to interfere with the operation of the lever at this time.

- P. Proceed to Section 11, on Actuator Stem Adjustment.

14. Manual Actuator Option

The manual type actuator is designed to close the valve by rotating the handwheel in a clockwise direction. Anti-rotation of the handwheel is obtained through a detente device located between handwheel (53) and retainer (87).

14.1 Disassembly Procedure

The disassembly procedure for manual actuator is similar to the procedure for spring diaphragm actuator see Section 8.1.

14.2 Maintenance

Routine maintenance of the manual actuator requires that a suitable lubricant be periodically applied to the handwheel powerscrew.

Bearings may require replacement due to service conditions or corrosion.

The replacement of the handwheel detent mechanism should be required.

14.3 Reassembly Procedure

There is no specific adjustment for the reassembly of manual actuator. For details see Figure 21.

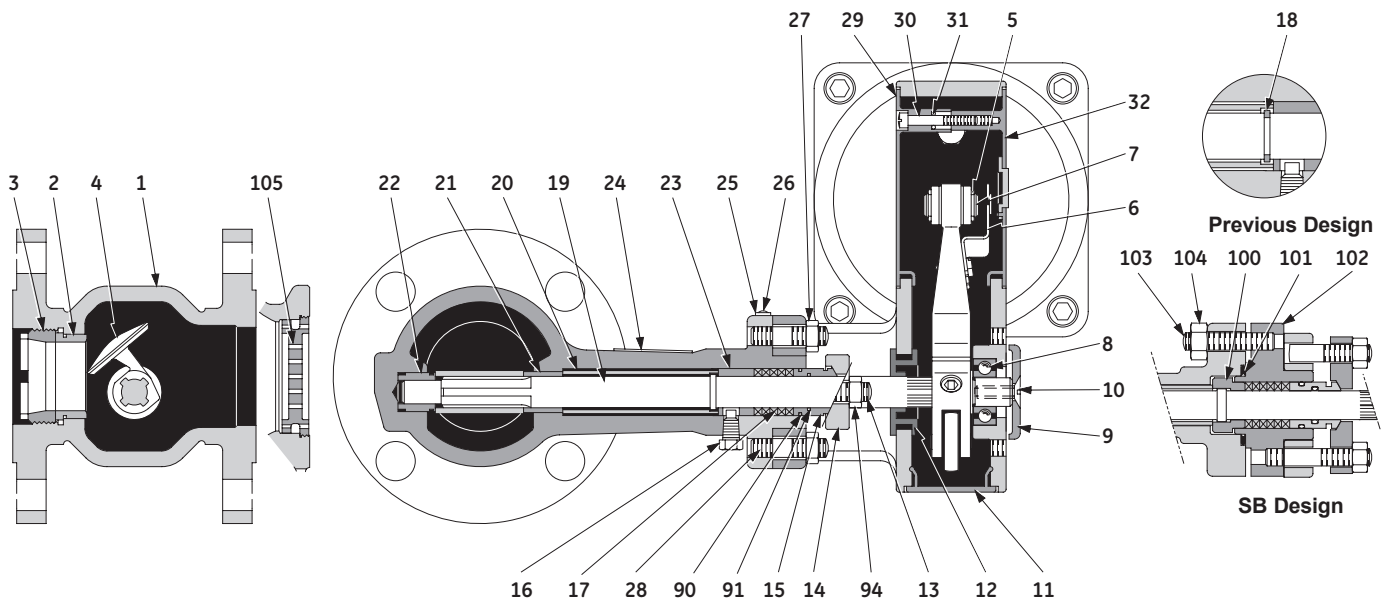

Figure 16

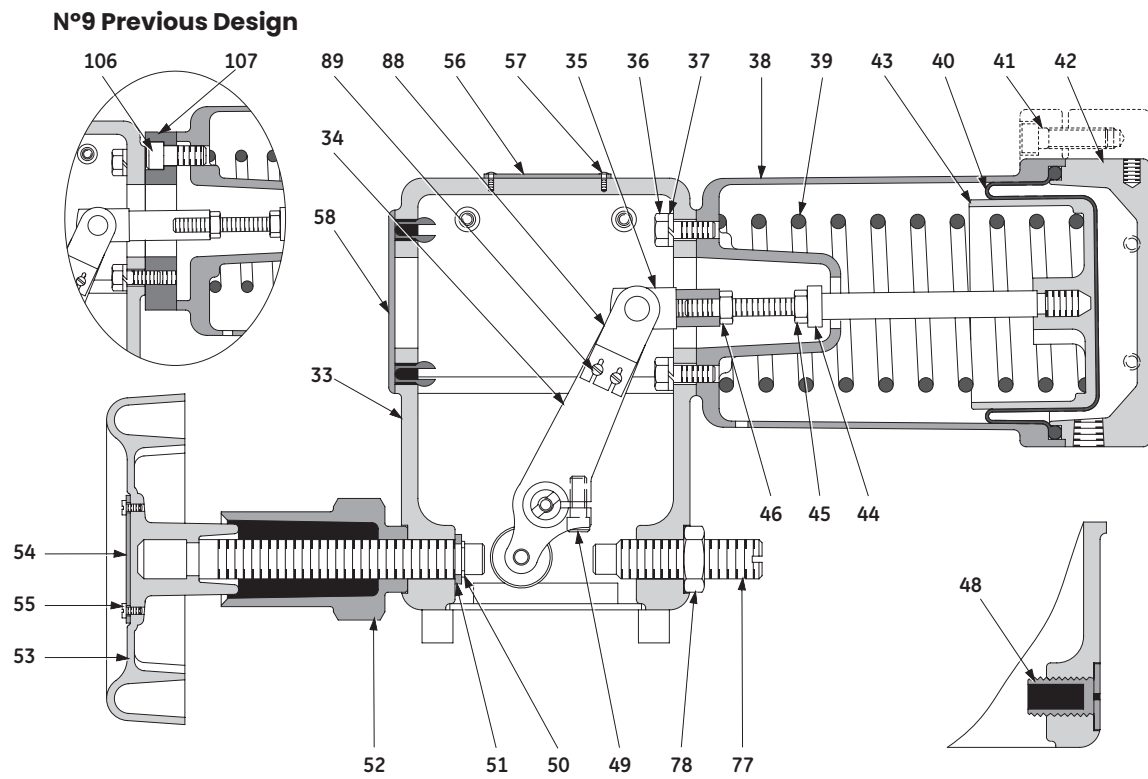

Figure 17

Parts Reference

Ref.	Qty.	Part Name	Ref.	Qty.	Part Name	Ref.	Qty.	Part Name
1	1	Body	28	2	Body Stud	56	1	Serial Plate
2	1	Seat Ring	29	1	Rear Cover	57	2	Plate Screw
3	1	Retainer	30	2	Cover Screw	58	1	Boss Cover
4	1	Plug	31	2	Screw Retainer	60	•	Counter-Flange
5	2	Clevis Pin Clip	32	1	Front Cover	61	•	Gasket
6	1	Indicator Dot	33	1	Yoke	64	•	Stud
7	1	Clevis Pin	34	1	Lever	67	•	Stud
8	1	Bearing	35	1	Clevis	68	•	Nut
9	1	Shaft Cover	36	4	Cap Screw	77	1	Limit Stop
10	1	Cover Screw	37	4	Lock Washer	78	1	Nut
11	1	Bottom Cover	38	1	Spring Barrel	88	1	Adjustable Indicator
12	1	Grommet	39	1	Spring	89	2	Indicator Screw
13	2	Packing Flange Stud	40	1	Diaphragm	90	1	Inner O-Ring
14	1	Packing Flange	41	4	Cap Screw	91	1	Outer O-Ring
15	1	Packing Follower	42	1	Diaphragm Case	92	1	Inner O-Ring
16	1	Safety Pin	43	1	Piston-Stem	93	1	Outer O-Ring
17	••	Packing	44	1	Lock Washer	94	2	Nut
18 ⁽¹⁾	1	Shaft Retaining Ring	45	1	Lock Nut	95	1	Inner O-Ring
19	1	Shaft	46	1	Lock Nut	96	1	Outer O-Ring
20	1	Spacer	48	•	Thread Plug	100	1	Stop Ring
21	1	Upper Guide	49	1	Lever Cap Screw	101	1	Body Gasket
22	1	Lower Guide	50	1	Truarc Ring	102	1	Bonnet
23	1	Packing Box Ring	51	1	Handwheel Washer	103	4	Bonnet Stud
24	1	Warning Plate	52	1	Handwheel Lock	104	4	Bonnet Nut
25	1	Flow Arrow	53	1	Handwheel Shaft	105	1	Lo-dB Plate
26	2	Plate Screw	54	1	Handwheel Plate	106 ⁽¹⁾	4	Adaptor Screw
27	2	Nut	55	2	Plate Screw	107 ⁽¹⁾	1	Adaptor

1. Applies to previous design only.

• Quantity varies according to option.

•• Quantity varies according to size and bonnet type. Confirm required quantity from valve serial records.

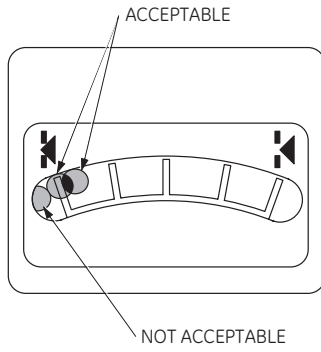
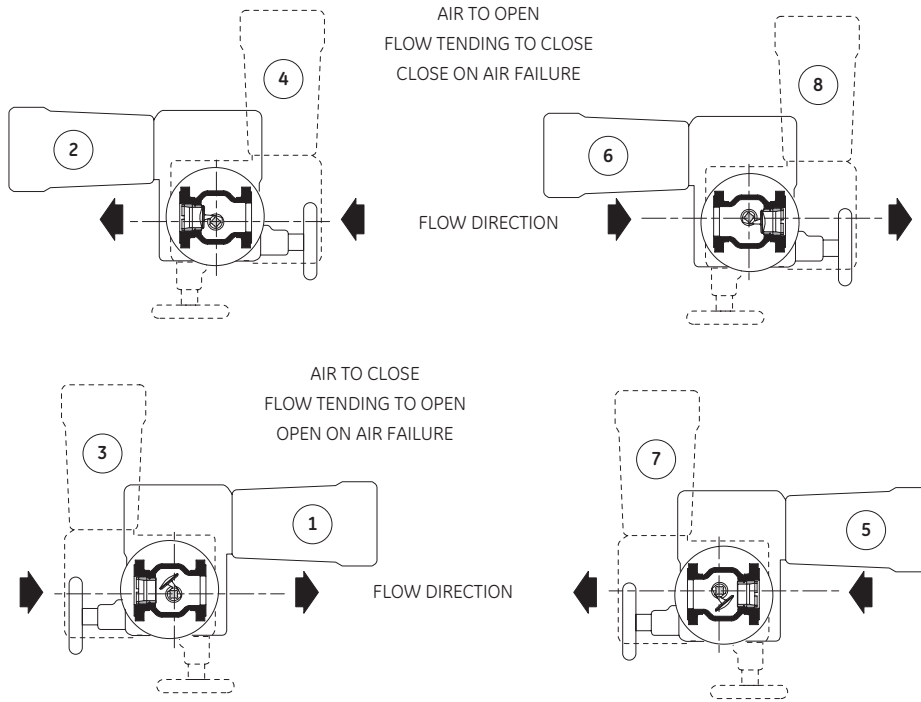

Figure 18



The body is shown behind the actuator.

Figure 19

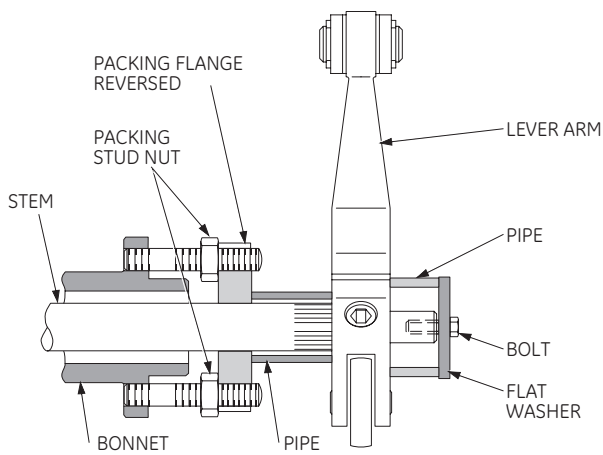

Figure 20

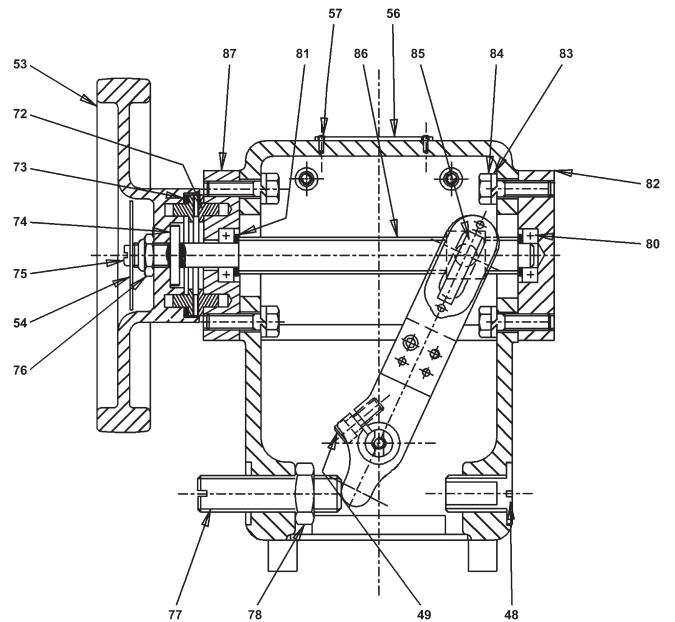
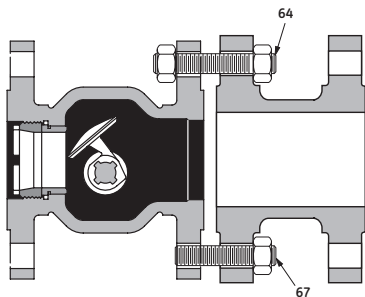

Figure 21

Flanged Bodies

Valve Rating		Long Stud (T) (64) Short Stud (G) (67)			Nuts	Long Stud (T) (64) Short Stud (G) (67)			Nuts	Long Stud (T) (64) Short Stud (G) (67)			Nuts
		Qty.	Length inches (mm)	Dia.		Qty.	Length inches (mm)	Dia.		Qty.	Length inches (mm)	Dia.	
		1" (DN 25)				1 1/2" (DN 40)				2" (DN 50)			
ANSI EN (ISO PN)	150 (20)	8T	2.50 (63.5)	1/2" (M14)	16	8T	2.75 (70.0)	1/2" (M14)	16	8T	3.25 (82.5)	5/8" (M16)	16
	300 (50)		3.00 (76.2)	5/8" (M16)			3.50 (88.9)	3/4" (M20)		16T	3.50 (88.9)		32
	600 (100)	8G	3.00 (76.2)		8	8G	3.50 (88.9)	8	8T + 8G	4.25 (108.0) 3.75 (95.2)	24		
EN DIN	PN 10	8T	(71.0)	M12	16	8T	(84.0)	M16	16	8T	(84.0)	M16	16
	PN 16												
	PN 25												
	PN 40												
		3" (DN 80)				4" (DN 100)				6" (DN 150)			
ANSI EN (ISO PN)	150 (20)	8T	3.50 (88.9)	5/8" (M16)	16	16T	3.50 (88.9)	5/8" (M16)	32	16T	4.00 (101.6)	3/4" (M20)	32
	300 (50)	16T	4.25 (108.0)	3/4" (M20)	32	16T	4.50 (114.3)	3/4" (M20)		24T	4.75 (120.6)		48
	600 (100)	12T + 4G	5.00 (127.0) 4.25 (108.0)		28	12T + 4G	5.75 (146.0) 5.00 (127.0)	7/8" (M24)		28	20T + 4G	6.75 (171.5) 6.00 (152.4)	1" (M27)
EN DIN	PN 10	16T	(84.0)	M16	32	16T	(84.0)	M16	32	16T	(102.0)	M20	32
	PN 16												
	PN 25												
	PN 40												
PN 63/64	N/A					(123.0)	M24		15T + 1G	(155.0) (120.0)	M30	31	
		8" (DN 200)				10" (DN 250)				12" (DN 300)			
ANSI EN (ISO PN)	150 (20)	16T	4.25 (108.0)	3/4" (M20)	32	24T	4.50 (114.3)	7/8" (M24)	48	24T	4.75 (120.6)	7/8" (M24)	48
	300 (50)	24T	5.50 (140.0)	7/8" (M24)	48	32T	6.25 (158.8)	1" (M27)	64	32T	6.75 (171.5)	1 1/8" (M30)	64
	600 (100)	20T + 4G	7.50 (190.5) 6.75 (171.5)	1 1/8" (M30)	44	N/A				N/A			
EN DIN	PN 10	16T	(102.0)	M20	32	24T	(106.0)	M20	48	24T	(106.0)	M20	48
	PN 16						(115.0)	M24			(115.0)	M24	
	PN 25	(123.0)	M27	(133.0)	M27								
	PN40	(137.0)	M27	(151.0)	M30		(151.0)	M30					



- 1/2" : 1/2" 13 UNC 2A/2B
- 5/8" : 5/8" 11 UNC 2A/2B
- 3/4" : 3/4" 10 UNC 2A/2B
- 7/8" : 7/8" 9 UNC 2A/2B
- 1" : 1" 8 UNC 2A/2B
- 1 1/8" : 1 1/8" 8 UNC 2A/2B
- 1 1/4" : 1 1/4" 8 UNC 2A/2B

Figure 22

