

D15S

Pressure Reducing Valve

Diaphragm-actuated with Cartridge Insert

APPLICATION

According to EN 806-2 pressure reducing valves of this type protect household water installations against excessive pressure from the supply. They can also be used for industrial or commercial applications within the range of their specification.

By installing a pressure reducing valve, pressurisation damage is avoided and water consumption is reduced.

The set pressure is also maintained constant, even when there is wide inlet pressure fluctuation.

Reduction of the operating pressure and maintaining it at a constant level minimizes flow noise in the installation.

APPROVALS

- DVGW
- NF
- WRAS (up to 23°C)
- KIWA (DN65-DN100)
- SVGW (DN65-DN100)

SPECIAL FEATURES

- Inlet pressure balancing – no influence on outlet pressure by fluctuating inlet pressure
- Patented cartridge solution for easy assembly and maintenance
- Two cartridge inserts for all nominal widths make warehousing efficient
- The adjustment spring is not in contact with the drinking water
- With inlet and outlet pressure gauge
- Functionality and performance have been confirmed by an accelerated life test with over 400,000 cycles (requirement acc. to EN1567: 200,000 cycles)
- Lead content of all materials is below permissible limits specified by DIN 50930-6
- All materials are UBA conform
- All materials are ACS approved



TECHNICAL DATA

Media	
Medium:	Drinking water
Optional medium:	Compressed air*1 acc. ISO 8573-1 class 2 in consideration of valid standards (e.g. EN 12502)
Connections/Sizes	
Connection sizes:	2 1/2", 3", 4", 6", 8"
Nominal sizes:	DN65, DN80, DN100, DN150, DN200 DN125 available with adapterflanges DN100/DN125
Pressure values	
Max. inlet pressure:	16 bar
Outlet pressure:	DN 65 - 100: 1.5 - 7.5 bar (6.5 bar acc. EN1567) DN 150 - 200: 1.5 - 8 bar
Nominal pressure:	PN 16
Min. pressure drop:	1.0 bar
Operating temperatures	
Max. operating temperature medium:	65 °C (WRAS approved up to 23°C)

Note: *1 As part of an installation being approved according to PED requirements, this product must also be certified.

CONSTRUCTION

Overview	Components	Materials
	1 Spring bonnet with adjustment screw	Ductile cast iron (EN-GJS-400-15 EN 1563), coated with PA (polyamide)
	2 Pressure gauge	-
	3 Screws and nuts	Stainless steel
	4 Housing with PN16 flanges per ISO 7005-2, EN 1092-2, face to face length acc. EN 558-1	Ductile cast iron (EN-GJS-400-15 EN 1563), coated with PA (polyamide)
Not depicted components		
	Adjustment spring	Spring steel
	Diaphragm and seals	EPDM
	Cartridge insert	Stainless steel
	Groove ring and sealing disc	EPDM

METHOD OF OPERATION

Spring loaded pressure reducing valves operate by means of a force equalising system. The force of a diaphragm operates against the force of an adjustment spring. If the outlet pressure and therefore diaphragm force fall because water is drawn, the then greater force of the spring causes the valve to open. The outlet pressure then increases until the forces between the diaphragm and the spring are equal again.

The inlet pressure has no influence in either opening or closing of the valve. Because of this, inlet pressure fluctuation does not influence the outlet pressure, thus providing inlet pressure balancing.

TRANSPORTATION AND STORAGE

Keep parts in their original packaging and unpack them shortly before use.

The following parameters apply during transportation and storage:

Parameter	Value
Environment:	clean, dry and dust free
Min. ambient temperature:	5 °C
Max. ambient temperature:	55 °C
Min. ambient relative humidity:	25 % *
Max. ambient relative humidity:	85 % *

*non condensing

INSTALLATION GUIDELINES

Setup requirements

- Install in horizontal pipework with spring bonnet directed upwards
- Install shut-off valves
- The installation location should be protected against frost and be easily accessible
 - Pressure gauge can be read off easily
 - Simplified maintenance and cleaning
- Install downstream of the filter or strainer
 - This position ensures optimum protection for the pressure reducing valve against dirt
- Provide a straight section of pipework of at least five times the nominal valve size after the pressure reducing valve (in accordance with EN 806-2)
- Requires regular maintenance in accordance with EN 806-5

Installation Example

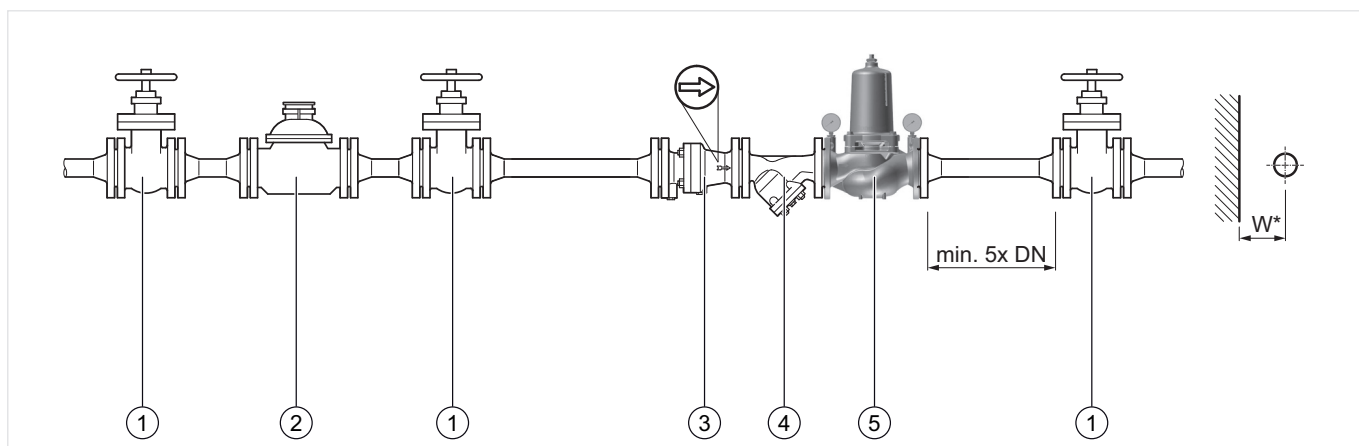

Fig. 1 Standard installation example for the pressure reducing valve

- 1 Shut-off valve
- 2 Water meter
- 3 Non return valve
- 4 Strainer
- 5 Pressure reducing valve

Connection sizes:					
DN	65	80	100	150	200
inch	2 1/2"	3"	4"	6"	8"
Distance in mm (W*):	120	130	145	200	230

* Required installation distances between the centerline of the pipework and the surrounding in dependency of the connection size.

TECHNICAL CHARACTERISTICS

kvs-Values

Connection sizes:					
DN	65	80	100	150	200
Inch	2 1/2"	3"	4"	6"	8"
DVGW registration number:	NW-6330CN0112			n.a.	
k _{VS} -value (m ³ /h):	49	51	56	230	255

Pressure drop characteristics

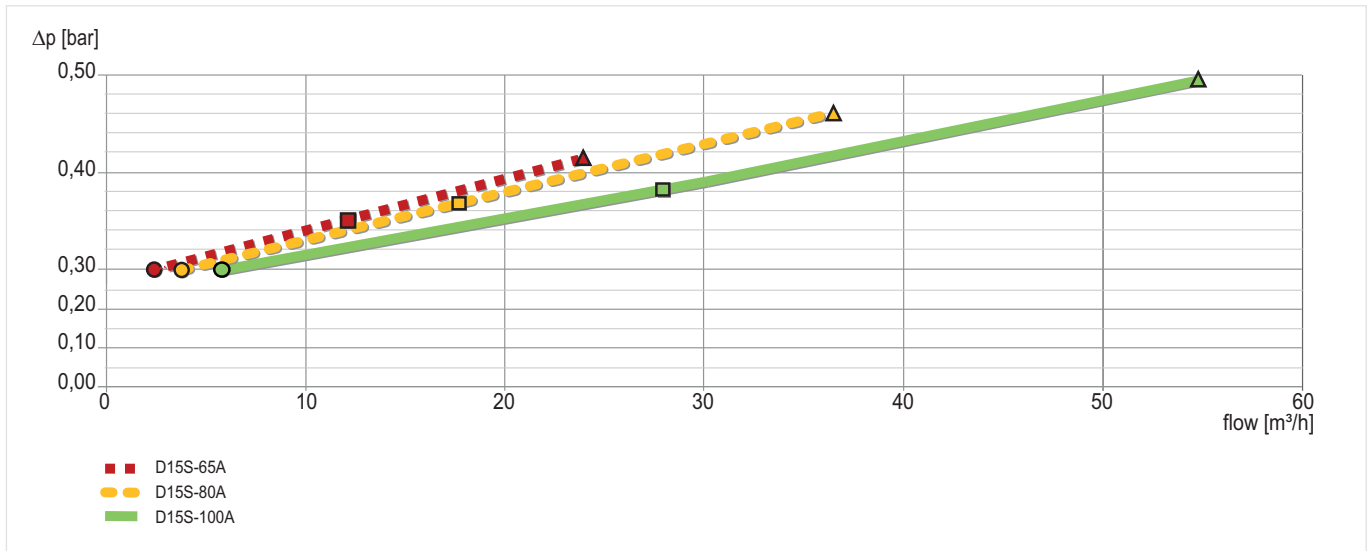

Fig. 2 Pressure drop within the valve in dependency of the flow rate and the used connection size (Sizes 65-100)

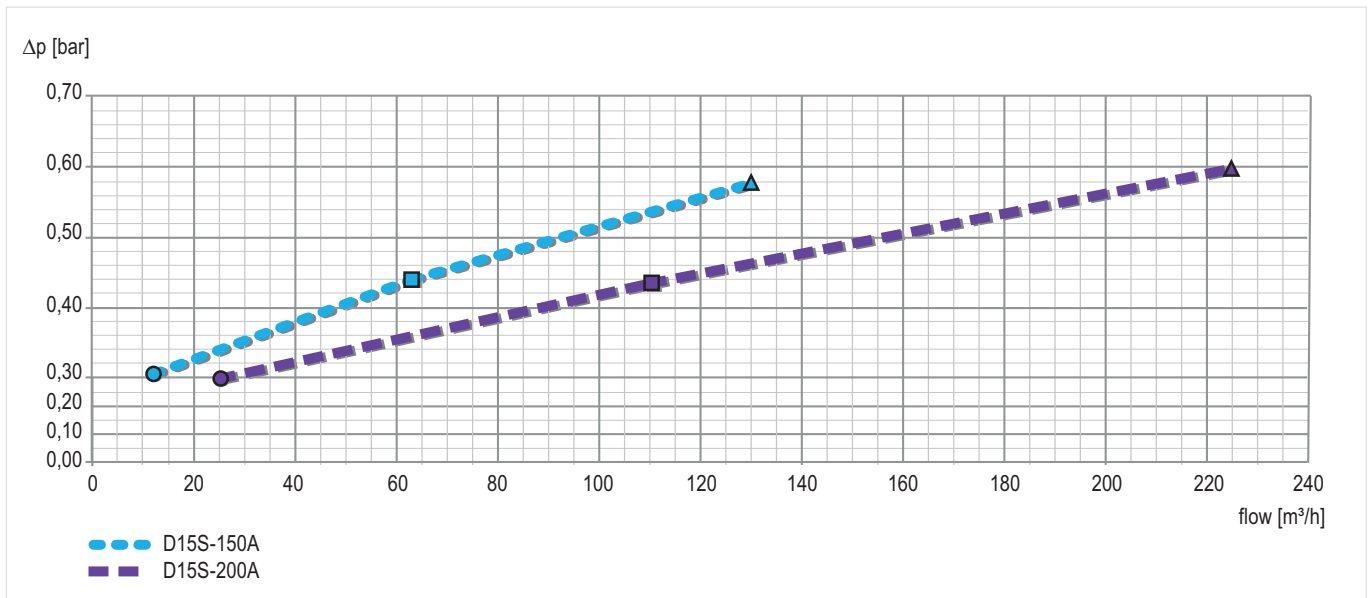
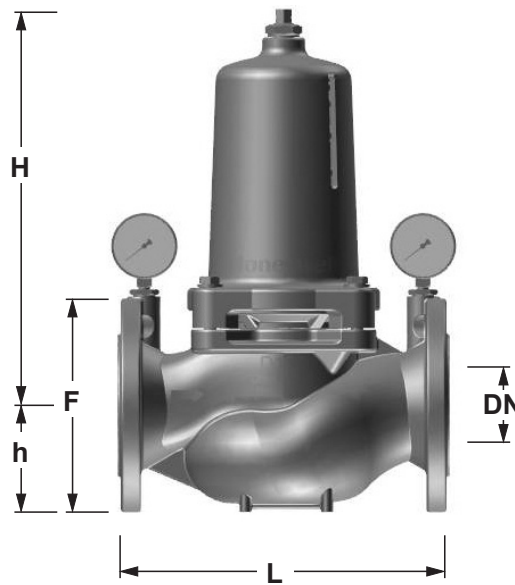

Fig. 3 Pressure drop within the valve in dependency of the flow rate and the used connection size (Sizes 150-200)

	DN65	DN80	DN100	DN150	DN200
● ≙ 10% of standard flow	2.4 m³/h	3.6 m³/h	5.6 m³/h	12.7 m³/h	22.6 m³/h
■ ≙ 1m/s flow rate	12 m³/h	18 m³/h	28 m³/h	63 m³/h	113 m³/h
▲ ≙ 2m/s flow rate = QN	24 m³/h	36 m³/h	56 m³/h	127 m³/h	226 m³/h

DIMENSIONS

Overview



Parameter		Values				
Connection sizes:	Inch	2 1/2"	3"	4"	6"	8"
Nominal sizes:	DN	65	80	100	150	200
Weight:	kg	30.5	32	34.5	110	135
Dimensions:	L	290	310	350	480	600
	H	370	370	370	541	534
	h	93	100	110	143	170
	F	185	200	220	285	340

Note: All dimensions in mm unless stated otherwise.

ORDERING INFORMATION

The following tables contain all the information you need to make an order of an item of your choice. When ordering, please always state the type, the ordering or the part number.

Options

The valve is available in the following sizes: 2 1/2", 3", 4", 6" and 8".

- standard
- not available

		D15S-...A
Flanges:	PN 16, ISO 7005-2, EN 1092-2, face to face length acc. EN558-1	•
Housing:	Ductile cast iron (EN-GJS-400-15 EN 1563), coated with PA (polyamide)	•

Note: ... = space holder for connection size

Note: Ordering number example for 2 1/2" and type A valve: D15S-65A

Accessories

	Description	Dimension	Part No.
	EXF125-A Extension flange DN125 Adapter flanges DN100 to DN125 Ductile iron, PN16 acc. ISO 7005-2 and EN1092-2. Overall length with adapter flanges (without bolts) DN125 L=416mm, DVGW approved, including bolts and nuts.		
			EXF125-A

Spare Parts

Pressure Reducing Valve D15S, from 2012 onwards

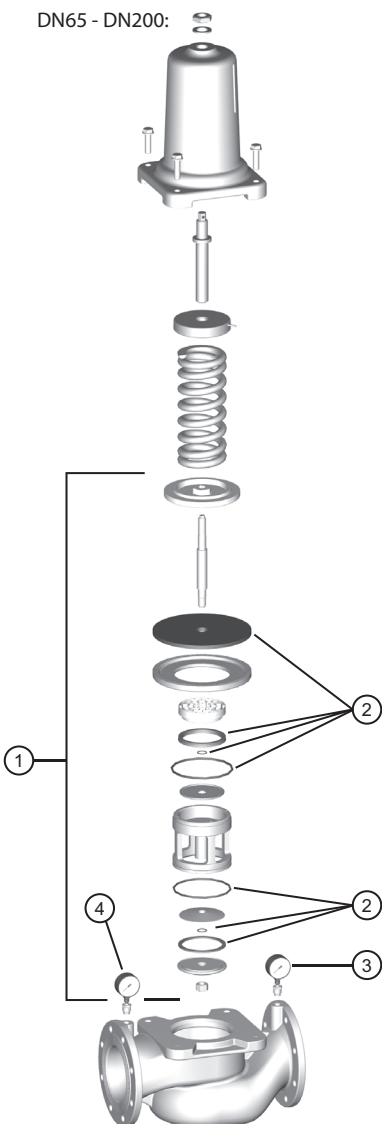
Overview	Description	Dimension	Part No.
	1 Valve insert complete		
		DN65 - DN100	0904120
		DN150 - DN200	0904139
	2 Set of seals complete		
		DN65 - DN100	0904121
		DN150 - DN200	0904140
	3 Pressure gauge		
		0 - 10 bar	M39M-A10
	4 Pressure gauge		
		0 - 16 bar	M39M-A16

Manufactured for and on behalf of the
 Environmental and Combustion Controls
 Division of Honeywell Technologies Sàrl, Z.A.
 La Pièce 16, 1180 Rolle, Switzerland
 by its Authorised Representative Honeywell GmbH
 ENOH-1049GE23 R0117
 Subject to change
 © 2017 Honeywell GmbH