

Steel ball valves, reduced bore with gears and actuators

welding/welding, EN (DIN), DN 100-600, with manual gear

Body: DN 10–500 Steel, P235GH (1.0345)
 DN 600–800 Steel, P355 NL1 (1.0566)/ GP240GH (1.0619)
 Ball: DN 10–600 Stainless steel, X5CrNi18-10 (1.4301)
 DN 700–800 Steel + stainless plating, ASTM A350 LF2+Ni
 Stem: Stainless steel, X8CrNiS18-9 (1.4305)
 Stem seals: FPM
 Ball seals: PTFE+C
 Operation: Valve is equipped with manual gear.
 For type and features of manual gear please refer to:
www.vexve.com/en/actuators.



Operating conditions

-30°C - +200°C
 Below 0 °C contact manufacturer

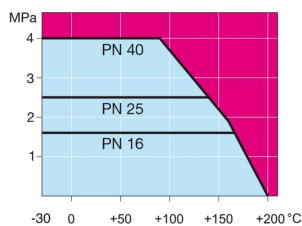

Not for steam

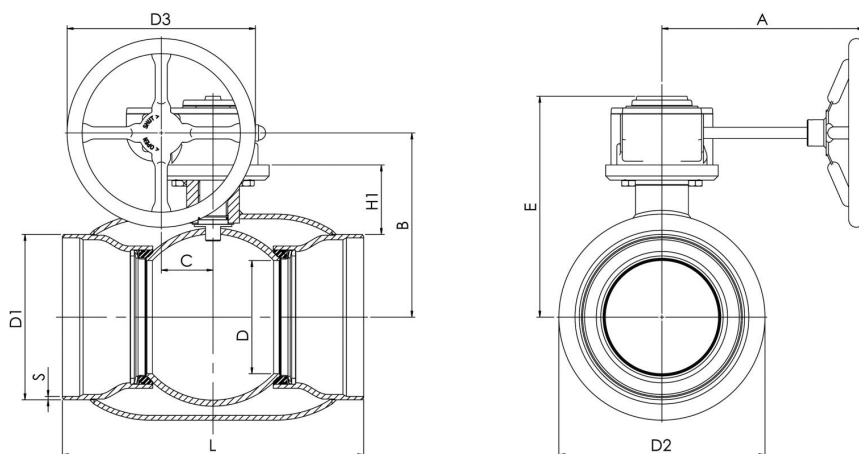

| Product no. Vexve | DN | PN | A | B | C | D | D1 | D2 | D3 | E | H | L | S | kg |
|-------------------|-----|----|-----|-----|-----|-----|-------|-------|-----|-----|-----|------|-----|------|
| 104100 | 100 | 25 | 186 | 196 | 53 | 80 | 114.3 | 146 | 125 | 239 | 105 | 325 | 3.6 | 18 |
| 104125 | 125 | 25 | 224 | 216 | 53 | 100 | 139.7 | 177.8 | 200 | 259 | 112 | 325 | 4 | 20 |
| 104150 | 150 | 25 | 224 | 236 | 53 | 125 | 168.3 | 219.1 | 200 | 279 | 118 | 350 | 4.5 | 25 |
| 104200 | 200 | 25 | 268 | 244 | 69 | 150 | 219.1 | 273 | 250 | 293 | 92 | 400 | 4.5 | 49 |
| 104250 | 250 | 25 | 301 | 294 | 97 | 200 | 273 | 355.6 | 300 | 345 | 108 | 530 | 5 | 94 |
| 104300 | 300 | 25 | 363 | 343 | 117 | 250 | 323.9 | 457 | 500 | 412 | 132 | 550 | 5.6 | 152 |
| 104350 | 350 | 25 | 363 | 418 | 117 | 290 | 355.6 | 508 | 500 | 487 | 192 | 686 | 6.3 | 212 |
| 104400 | 400 | 25 | 444 | 500 | 138 | 340 | 406.4 | 610 | 500 | 573 | 242 | 762 | 7 | 293 |
| 104500 | 500 | 25 | 475 | 577 | 180 | 390 | 508 | 660 | 500 | 648 | 259 | 914 | 7 | 467 |
| 104600 | 600 | 25 | 475 | 644 | 180 | 489 | 610 | 813 | 500 | 715 | 274 | 1065 | 7.1 | 1025 |

Steel ball valves, reduced bore with gears and actuators

flange/flange, DN 100-600, with manual gear

Body: DN 10-500 Steel, P235GH (1.0345)
 DN 600-800 Steel, P355 NL1 (1.0566)/ GP240GH (1.0619)
 Ball: DN 10-600 Stainless steel, X5CrNi18-10 (1.4301)
 DN 700-800 Steel + stainless plating, ASTM A350 LF2+Ni
 Stem: Stainless steel, X8CrNiS18-9 (1.4305)
 Stem seals: FPM
 Ball seals: PTFE+C
 Flanges: EN 1092-1
 Available PN 10, 16, 25, 40
 Length: EN 558-1 (DIN 3202) DN 15-200
 Operation: Valve is equipped with manual gear.
 For type and features of manual gear please refer to:
www.vexve.com/en/actuators.



Operating conditions

-30°C - +200°C
 Below 0 °C contact manufacturer

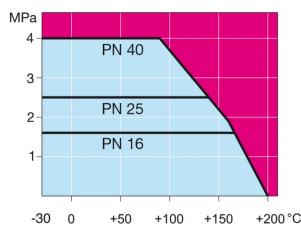

Not for steam

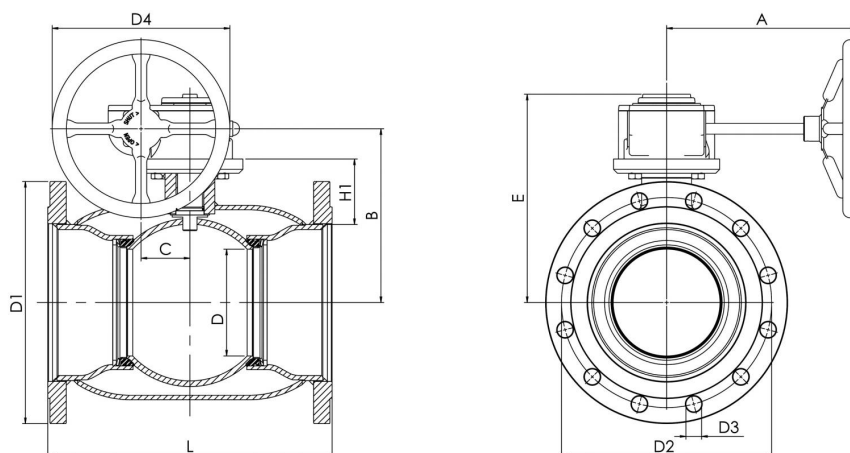

| Product no. Vexve | DN | PN | A | B | C | D | D1 | D2 | D3 | D4 | E | H1 | L | Holes | kg |
|-------------------|-----|----|-----|-----|-----|-----|-----|-----|----|-----|-----|-----|------|-------|------|
| 104101 | 100 | 16 | 186 | 206 | 53 | 80 | 220 | 180 | 18 | 125 | 248 | 114 | 300 | 8 | 23 |
| 104126 | 125 | 16 | 224 | 216 | 53 | 100 | 250 | 210 | 18 | 200 | 258 | 112 | 325 | 8 | 30 |
| 104151 | 150 | 16 | 224 | 236 | 53 | 125 | 285 | 240 | 22 | 200 | 279 | 118 | 350 | 8 | 37 |
| 104201 | 200 | 16 | 268 | 244 | 69 | 150 | 340 | 295 | 22 | 250 | 293 | 92 | 400 | 12 | 68 |
| 104251 | 250 | 16 | 301 | 294 | 97 | 200 | 405 | 355 | 26 | 300 | 345 | 108 | 500 | 12 | 122 |
| 104301 | 300 | 16 | 363 | 343 | 118 | 250 | 460 | 410 | 26 | 500 | 412 | 115 | 500 | 12 | 190 |
| 104351 | 350 | 16 | 363 | 418 | 118 | 290 | 520 | 470 | 26 | 500 | 487 | 192 | 706 | 16 | 268 |
| 104401 | 400 | 16 | 444 | 500 | 138 | 340 | 580 | 525 | 30 | 500 | 573 | 242 | 810 | 16 | 365 |
| 104501 | 500 | 16 | 475 | 577 | 180 | 390 | 715 | 650 | 33 | 500 | 648 | 259 | 978 | 20 | 595 |
| 104601 | 600 | 16 | 475 | 644 | 180 | 489 | 840 | 770 | 36 | 500 | 715 | 274 | 1130 | 20 | 1230 |